

**TL280LE(R) / TL280LEX(R) /  
TL280LE-EU / TL280LE-LAT /  
TL280LE-AU**

Internet and LTE/HSPA Dual-Path Alarm  
Communicator

**LE2080(R) / LE2080X(R) / LE2080-  
EU / LE2080-LAT / LE2080-AU**

LTE/HSPA Alarm Communicator

**3G2080(R)E**

HSPA Cellular Alarm Communicator

**TL2803G(R)E**

Internet and HSPA Dual-Path Alarm Communicator

**TL280(R)E**

Internet Alarm Communicator



## Approvals information

NOTICE TO USERS, INSTALLERS, AUTHORITIES HAVING JURISDICTION AND OTHER INVOLVED PARTIES  
This product incorporates field-programmable software. In order for the product to comply with the requirements in CAN/ULC-S559.

Standard for Control Units for Fire Alarm Systems, certain programming features or options must be limited to the specific values or not used at all as indicated below.

Program Feature or Option	Permitted in ULC-S559	Possible Settings	Settings Permitted in S559
Supervision (Active)	Yes	180s 200s 180s (90s Heartbeat) 300s	180s (90s Heartbeat) (Active)
Supervision (Passive)	Yes	Daily, Weekly, Monthly test transmissions	Daily Test Enabled (passive)
SMS Command and Control	No	Enable/disable	Disabled

In Connect24, the installer must select an account type. These are the account types available for ULC in C24: ULC Commercial Fire – Active  
ULC Commercial Burg – Active  
ULC Commercial Fire – Passive  
ULC Commercial Burg – Passive  
ULC Residential – All configurations  
ULC Commercial Fire Active Dual channel  
ULC Commercial Fire Passive Dual channel

### IMPORTANT INSTALLATION NOTICE - TL280LE-AU / LE2080-AU

The radio requires an appropriate network provider to be selected during the installation process.

Telstra: Enter Installer's programming [\*][8][Installer's code][851][019], and enter 01 to select Telstra.

Vodafone: Enter Installer's programming [\*][8][Installer's code][851][019], and enter 02 to select Vodafone.

If Optus is the carrier, select the Telstra profile 01.

Spark: Enter Installer's programming [\*][8][Installer's code][851][019], and enter 03 to select Spark.

Failure to select the correct network profile during the initial installation may interfere with SIM card provisioning or the radio's ability to remain attached to the home network.

## **WARNING: Installer please read carefully**

### **Note to Installers**

The warnings on this page contain vital information. As the only individual in contact with system users, it is the installer's responsibility to bring each item in this warning to the attention of all users of this system.

### **System Failures**

This system has been carefully designed to be as effective as possible. There are circumstances, however, involving fire, burglary, or other types of emergencies where it may not provide protection. Any alarm system of any type may be compromised deliberately or may fail to operate as expected for a variety of reasons. Some, but not all, of the reasons may be:

#### **Access by Intruders**

Intruders may enter through an unprotected access point, circumvent a sensing device, evade detection by moving through an area of insufficient coverage, disconnect a warning device, or interfere with or prevent the proper operation of the system.

#### **Component Failure**

Although every effort has been made to make this system as reliable as possible, the system may fail to function as intended due to the failure of a component.

#### **Compromise of Radio Frequency (Wireless) Devices**

Signals may not reach the receiver under all circumstances which could include metal objects placed on or near the radio path or deliberate jamming or other inadvertent radio signal interference.

#### **Criminal Knowledge**

This system contains security features which were known to be effective at the time of manufacture. It is possible for persons with criminal intent to develop techniques which reduce the effectiveness of these features. It is important that the security system be reviewed periodically to ensure that its features remain effective and that it is updated or replaced if it is found that it does not provide the protection expected.

#### **Failure of Replaceable Batteries**

This system's wireless transmitters have been designed to provide several years of battery life under normal conditions. The expected battery life is a function of the device environment, usage, and type. Ambient conditions such as high humidity, high or low temperatures, or large temperature fluctuations may reduce the expected battery life. While each transmitting device has a low battery monitor which identifies when the batteries need to be replaced, this monitor may fail to operate as expected. Regular testing and maintenance will keep the system in good operating condition.

#### **Inadequate Installation**

A security system must be installed properly in order to provide adequate protection. Every installation should be evaluated by a security professional to ensure that all access points and areas are covered. Locks and latches on windows and doors must be secure and operate as intended. Windows, doors, walls, ceilings and other building materials must be of sufficient strength and construction to provide the level of protection expected. A reevaluation must be done during and after any construction activity. An evaluation by the fire and/or police department is highly recommended if this service is available.

#### **Inadequate Testing**

Most problems that would prevent an alarm system from operating as intended can be found by regular testing and maintenance. The complete system should be tested weekly and immediately after a break-in, an attempted break-in, a fire, a storm, an earthquake, an accident, or any kind of construction activity inside or outside the premises. The testing should include all sensing devices, keypads, consoles, alarm indicating devices, and any other operational devices that are part of the system.

#### **Insufficient Time**

There may be circumstances when the system will operate as intended, yet the occupants will not be protected from an emergency due to their inability to respond to the warnings in a timely manner. If the system is remotely monitored, the response may not occur in time to protect the occupants or their belongings.

#### **Motion Detectors**

Motion detectors can only detect motion within the designated areas as shown in their respective installation instructions. They cannot discriminate between intruders and intended occupants. Motion detectors do not provide volumetric area protection. They have multiple beams of detection and motion can only be detected in unobstructed areas covered by these beams. They cannot detect motion which occurs behind walls, ceilings, floor, closed doors, glass partitions, glass doors or windows. Any type of tampering whether intentional or unintentional such as masking, painting, or spraying of any material on the lenses, mirrors, windows or any other part of the detection system will impair its proper operation.

Passive infrared motion detectors operate by sensing changes in temperature. However their effectiveness can be reduced when the ambient temperature rises near or above body temperature or if there are intentional or unintentional sources of heat in or near the detection area. Some of these heat sources could be heat-

ers, radiators, stoves, barbecues, fireplaces, sunlight, steam vents, lighting and so on.

#### **Power Failure**

Control units, intrusion detectors, smoke detectors and many other security devices require an adequate power supply for proper operation. If a device operates from batteries, it is possible for the batteries to fail. Even if the batteries have not failed, they must be charged, in good condition and installed correctly. If a device operates only by AC power, any interruption, however brief, will render that device inoperative while it does not have power. Power interruptions of any length are often accompanied by voltage fluctuations which may damage electronic equipment such as a security system. After a power interruption has occurred, immediately conduct a complete system test to ensure that the system operates as intended.

#### **Security and Insurance**

Regardless of its capabilities, an alarm system is not a substitute for property or life insurance. An alarm system also is not a substitute for property owners, renters, or other occupants to act prudently to prevent or minimize the harmful effects of an emergency situation.

#### **Smoke Detectors**

Smoke detectors that are a part of this system may not properly alert occupants of a fire for a number of reasons, some of which follow. The smoke detectors may have been improperly installed or positioned. Smoke may not be able to reach the smoke detectors, such as when the fire is in a chimney, wall or roof, or on the other side of closed doors. Smoke detectors may not detect smoke from fires on another level of the residence or building.

Every fire is different in the amount of smoke produced and the rate of burning. Smoke detectors cannot sense all types of fires equally well. Smoke detectors may not provide timely warning of fires caused by carelessness or safety hazards such as smoking in bed, violent explosions, escaping gas, improper storage of flammable materials, overloaded electrical circuits, children playing with matches, or arson. Even if the smoke detector operates as intended, there may be circumstances when there is insufficient warning to allow all occupants to escape in time to avoid injury or death.

#### **Telephone Lines**

If telephone lines are used to transmit alarms, they may be out of service or busy for certain periods of time. Also an intruder may cut the telephone line or defeat its operation by more sophisticated means which may be difficult to detect.

#### **Warning Devices**

Warning devices such as sirens, bells, horns, or strobes may not warn people or waken someone sleeping if there is an intervening wall or door. If warning devices are located on a different level of the residence or premise, then it is less likely that the occupants will be alerted or awakened. Audible warning devices may be interfered with by other noise sources such as stereos, radios, televisions, air conditioners, other appliances, or passing traffic. Audible warning devices, however loud, may not be heard by a hearing-impaired person.

# Table of Contents

<b>Approvals information</b> .....	<b>2</b>
<b>Table of Contents</b> .....	<b>4</b>
<b>General</b> .....	<b>6</b>
Safety Information .....	6
<b>Model Information</b> .....	<b>6</b>
<b>Panel Mounting</b> .....	<b>9</b>
<b>Features</b> .....	<b>9</b>
<b>Technical Specifications</b> .....	<b>9</b>
<b>EN50131-1 Installation Requirements</b> .....	<b>10</b>
<b>Ratings Compatibility</b> .....	<b>11</b>
<b>Pre Installation Configuration</b> .....	<b>12</b>
Encryption .....	12
<b>Communicator Installation Configuration</b> .....	<b>12</b>
Installing the Ethernet Cable (TL Models Only) .....	12
Inserting and Removing the SIM Card .....	13
Running the RS-232 Cable (R models only) .....	13
<b>Installing Communicator in Panel</b> .....	<b>14</b>
Installing the Communicator with HS20XX Panels .....	14
<b>Communicator Placement Test</b> .....	<b>17</b>
Cellular Communicator Models Only .....	17
Cellular Signal Strength Display - LCD Keypad only .....	17
<b>Initial Panel Programming</b> .....	<b>18</b>
Keypad Data Display .....	18
Entering HEX values at keypad .....	18
Entering ASCII Characters at keypad .....	18
HS2016/2016-4/2032/2064/2128 Initial Programming .....	18
Activating the Communicator with C24 Communications .....	18
Important Installation Notice - TL280LE-AU / LE2080-AU .....	18
<b>SMS Command and Control</b> .....	<b>19</b>
SMS Commands .....	19
<b>Communicator Status LEDs</b> .....	<b>19</b>
Yellow Trouble LED .....	19
Panel Supervision Trouble (2 Flashes) .....	20
Cellular Trouble (5 Flashes) .....	20
Ethernet Trouble (6 Flashes) .....	20
Receiver Not Available (7 Flashes) .....	20
Receiver Supervision Trouble (8 Flashes) .....	20
FTC Trouble (9 Flashes) .....	20
Module Configuration Trouble (12 Flashes) .....	20
Red Network Connection Status LED .....	20
(Green LED 1) (Green LED 2) and (Yellow LED) Signal Strength .....	20
<b>Communicator Reset/Update</b> .....	<b>21</b>
Factory Defaults Reset .....	21
Firmware Update .....	21
<b>Communicator Troubleshooting</b> .....	<b>22</b>

---

<b>Ethernet/Cellular Programming Options</b> .....	<b>24</b>
System Options .....	24
Programming Options .....	25
Communications Reporting Codes .....	29
System Test Options .....	30
Ethernet Receiver 1 Options .....	31
Ethernet Receiver 2 Options .....	32
Ethernet Options .....	33
Cellular Receiver 1 Options .....	34
Cellular Receiver 2 Options .....	34
Cellular Options .....	35
SMS Event Notification/Command and Control Options .....	36
External Event Label Programming .....	45
Receiver Diagnostic Testing .....	47
System Information (Read Only) .....	48
System Reset Defaults .....	52
<b>Communicator Programming Worksheets</b> .....	<b>54</b>
System Options .....	54
Programming Options .....	54
System Test Options .....	55
Ethernet Receiver 1 Options .....	55
Ethernet Receiver 2 Options .....	55
Ethernet Options .....	56
Cellular Receiver 1 Options .....	56
Cellular Receiver 2 Options .....	56
Cellular Options .....	56
Command and Control Options .....	57
External Event Label Programming .....	61
Receiver Diagnostic Testing .....	66
System Information (Read Only) .....	66
System Reset Defaults .....	66
<b>Limited Warranty</b> .....	<b>67</b>
<b>EULA</b> .....	<b>68</b>
<b>Regulatory Information</b> .....	<b>70</b>

## General

This installation manual must be used in conjunction with the control panel manual. All the safety instructions specified within that manual must be observed. The control panel is referenced as the "panel" throughout this document. This installation guide provides the basic wiring, programming and troubleshooting information.

This alarm communicator is a fixed, wall-mounted unit, and must be installed in the location specified in these instructions. The equipment enclosure must be fully assembled and closed, with all the necessary screws / tabs, and secured to a wall before operation. Internal wiring must be routed in a manner that prevents:

- Excessive strain on wire and on terminal connections,
- Interference between power limited and non power limited wiring,
- Loosening of terminal connections, or
- Damage of conductor insulation.

**WARNING: Never install this equipment during a lightning storm!**

### Safety Information

The installer must instruct the system user on each of the following:

- Do not attempt to service this product. Opening or removing covers may expose the user to dangerous voltages or other risks.
- Any servicing shall be referred to skilled persons only.
- Use authorized accessories only with this equipment.
- Do not stay close to the equipment during device operation.
- Do not touch the external antenna.

## Model Information

This manual covers the following models of alarm communicators:

### LTE - North America

Models TL280LER, TL280LE, LE2080R, and LE2080 support LTE bands B2, B4, B5, B12, B13 and WCDMA bands B2 and B5

### LTE - Europe

Models TL280LE-EU, LE2080-EU support LTE bands 1, 3, 7, 8, 20, 28A, HSPA, bands 1, 3, 8, and 2G bands 3 and 8.

### WCDMA - North and South America, Mexico

Models TL2803GRE, TL2803GE, TL280RE, TL280E, 3G2080RE, 3G2080E, TL2803GE-LAT, 3G2080E-LAT support WCDMA bands B2 and B5 (850/1900MHz Operation).

### LTE - LATAM and Mexico

Models TL280LE-LAT and LE2080-LAT support LTE bands 1, 2, 3, 4, 5, 7 and 28. WCDMA bands 1, 2, 4 and 5. 2G bands 2, 3, 5 and 8.

### LTE - Australia and New Zealand

LTE Bands 1, 3, 5, 8, 9, 18(26), 19 and 28. WCDMA Bands 1, 5, 6, 8 and 19.

**NOTE:** Only models TL2803GE and 3G2080E are CNC certified for use in Argentina.

### WCDMA - Australia, New Zealand and Brazil

Models TL2803GRE-AU, TL2803GE-AU, TL280RE-AU, TL280E-AU, 3G2080RE-AU, 3G2080E-AU support WCDMA 850 /2100 MHz.

The UL/ULC certified modes of communicators TL280LERX, TL280LEX, LE2080RX, LE2080X are compatible with HS2016, HS2016-4, HS2032, HS2064, and HS2128 panels SW Ver 1.0x to 1.5x.

Table 1: LTE North America - LE910-NA1

Band	Transmit Band (Tx)	Receive Band (Rx)
LTE B2	1850 - 1910 MHz	1930 - 1990 MHz
LTE B4	1710 - 1765 MHz	2110 - 2155 MHz
LTE B5	824 - 849 MHz	869 - 894 MHz
LTE B12	698 - 716 MHz	728 - 746 MHz
LTE B13	777 - 787 MHz	746 - 756 MHz
UMTS B2	1850 - 1910 MHz	1930 - 1990 MHz
UMTS B5	824 - 840 MHz	869 - 894 MHz

Table 2: LTE North America - LE910C1-SAX

Band	Transmit Band (Tx)	Receive Band (Rx)
LTE B2	1850 - 1910 MHz	1930 - 1990 MHz
LTE B4	1710 - 1755 MHz	2110 - 2155 MHz
LTE B12	698 - 716 MHz	746 - 756 MHz
LTE B66	1710 - 1780 MHz	2110 - 2200 MHz

Table 3: LTE Europe - LE910-C1-EUX

Band	Transmit Band (Tx)	Receive Band (Rx)
LTE B1	1920 - 1980 MHz	2100 - 2170 MHz
LTE B3	1710 - 1785 MHz	1930 - 1990 MHz
LTE B7	2500 - 2170 MHz	2620 - 2690 MHz
LTE B8	880 - 862 MHz	791 - 821 MHz
LTE B28A	703 - 733 MHz	758 - 788 MHz
WCDMA B1	1920 - 1980 MHz	2110 - 2170 MHz
WCDMA B3	1710 - 1785 MHz	1805 - 1880 MHz
WCDMA B8	880 - 915 MHz	925 - 960 MHz
2G DCS1800	1710 - 1785 MHz	1805 - 1880 MHz
2G EGSM 900	880 - 915 MHz	925 - 960 MHz

Table 4: 3G Global - UE910-NAR/EUR and HE910-EUR

Band	Transmit Band (Tx)	Receive Band (Rx)
WCDMA B1	1920 - 1980 MHz	2110 - 2170 MHz
WCDMA B2	1850 - 1910 MHz	1930 - 1990 MHz
WCDMA B3	1710 - 1785 MHz	1805 - 1880 MHz
WCDMA B8	880 - 915 MHz	925 - 960 MHz
PCS 1900	1850.2 - 1909.8 MHz	1930.2 - 1989.8 MHz
DCS 1800	1710 - 1785 MHz	1805 - 1880 MHz
GSM 850	824.2 - 848.8 MHz	869.2 - 893.8 MHz
EGSM 900	880 - 915 MHz	925 - 960 MHz

Table 5: Australia / New Zealand LTE - LE910C1-AP

Band	Transmit Band (Tx)	Receive Band (Rx)
LTE B1	1920 - 1980 MHz	2110 - 2170 MHz
LTE B3	1710 - 1785 MHz	1805 - 1880 MHz
LTE B5	824 - 849 MHz	869 - 894 MHz
LTE B9	1749.9 - 1784.9 MHz	1844.9 - 1879.9 MHz
LTE B18	815 - 830 MHz	860 - 875 MHz
LTE B19	830 - 845 MHz	875 - 890 MHz
LTE B28	703 - 748 MHz	758 - 803 MHz
WCDMA B1	1920 - 1980 MHz	2110 - 2170 MHz
WCDMA B5	824 - 849 MHz	869 - 894 MHz
WCDMA B6	830 - 840 MHz	875 - 885 MHz
WCDMA B8	880 - 915 MHz	925 - 960 MHz
WCDMA B19	830 - 845 MHz	875 - 890 MHz

Table 6: Mexico, LATAM and Brazil LE910C1-LA

Band	Transmit Band (Tx)	Receive Band (Rx)
LTE B1	1920 - 1980 MHz	2110 - 2170 MHz
LTE B2	1850 - 1910 MHz	1930 - 1990 MHz
LTE B3	1710 - 1785 MHz	1805 - 1880 MHz
LTE B4	1710 - 1755 MHz	2110 - 2155 MHz
LTE B5	824 - 849 MHz	869 - 894 MHz
LTE B7	2500 - 2570 MHz	2620 - 2690 MHz
LTE B28	703 - 748 MHz	758 - 803 MHz
WCDMA B1	1920 - 1980 MHz	2110 - 2170 MHz
WCDMA B2	1850 - 1910 MHz	1930 - 1990 MHz
WCDMA B4	1710 - 1755 MHz	2110 - 2155 MHz
WCDMA B5	824 - 849 MHz	869 - 894 MHz
2G B2	1850 - 1910 MHz	1930 - 1990 MHz
2G B3	1710 - 1785 MHz	1805 - 1880 MHz
2G B5	824 - 849 MHz	869 - 894 MHz
2G B8	880 - 915 MHz	925 - 960 MHz

References to model names **TL280(R)E**, **TL2803G(R)E**, **3G2080(R)E**, **TL280LE(R)**, **TL280LEX(R)**, **LE2080(R)**, and **LE2080X(R)** throughout this manual apply to all specified models unless stated differently. Models ending in "R" include a built-in RS-232 interface for connecting to local third-party applications.

**3G2080(R)E**: Is a HSPA (3G) cellular alarm communicator that sends alarm communication to Sur-Gard System I-IP, II, III (SG-DRL3IP), IV (SG-DRL4IP), and 5 (SG-DRL5IP) central station receivers via a HSPA(3G)/GPRS digital cellular network. **TL2803G(R)E**: Is a dual-path HSPA(3G) Ethernet alarm communicator that sends alarm communication to Sur-Gard System I-PI, II, III, IV, and 5 central station receivers through Ethernet/Internet or a HSPA(3G)/GPRS digital cellular network. **TL280(R)E**: Is an Ethernet alarm communicator that sends alarm communication to Sur-Gard System I-IP, II, III (SG-DRL3IP), IV (SG-DRL4IP), and 5 (SG-DRL5IP) central station receivers via Ethernet/Internet.

**LE2080(R)**: is an LTE (4G) cellular alarm communicator with HSPA(3G) fallback support that sends alarm communications to Sur-Gard System I-IP, II, III (SG-DRL2IP, IV (SG-DRL4IP) and 5 (SG-DRL5IP) central station receivers via an LTE (4) /HSPA(3G) digital cellular network.

**TL280LE(R) / TL280LEX(R)**: Is a dual path LTE (4G) Ethernet alarm communicator that sends alarm communications to Sur-Gard System I-IP, II, III (SG-DRL3IP, IV (SG-DRL4IP) and 5 (SG-DRL5IP) central station receivers via Ethernet/Internet or a LTE(4)/HSPA(3G) digital cellular network. HSPA (3G) only available on TL280LE(R) products.

The communicator can be used as either a backup or primary communicator. The communicator supports Internet Protocol (IP) transmission of panel and communicator events over Ethernet/Internet and/or HSPA/GPRS.

The cellular performance of the **LE2080(R)**, **TL280LE(R)**, **3G2080(R)E** or **TL2803G(R)E** communicators depend greatly on the LTE(4G)/HSPA(3G) network coverage in the local area. A communicator placement test must be performed prior to mounting the unit. A minimum of one green LED must be ON for good signal strength. Optional 3G/2G and LTE/3G antenna extension kits are available to improve signal strength if required. GS-15ANTQ, GS-25ANTQ and GS-50ANTQ kits are available for 3G/2G products and LTE-15ANT, LTE-25ANT, LTE-50ANT extension kits are available for LTE/3G products.

**NOTE:** Prior to installation, confirm with the local service provider that the network is available and active in the area where the communicator will be installed, and that radio signal strength (CSQ) is adequate.

## Panel Mounting

The following communicators are compatible with HS2016, HS2016-4, HS2032, HS2064, and HS2128 panels:

- **3G2080(R)E** (HSPA(3G)/GPRS only)
- **TL2803G(R)E** (Ethernet/Internet + HSPA(3G)/GPRS dual-path)
- **TL280(R)E** (Ethernet/Internet only)
- **LE2080(R)** (LTE(4G)/HSPA(3G) only)
- **TL280LE(R)** (Ethernet/Internet + LTE(4G)/HSPA(3G))
- **TL280LE-EU** (Ethernet/Internet + LTE(4G)/HSPA(3G)/2G)
- **LE2080-EU** (LTE(4G)/HSPA(3G)/2G only)
- **TL280LE-AU** (Ethernet/Internet + LTE(4G)/HSPA(3G))
- **LE2080-AU** (LTE(4G)/HSPA(3G))
- **TL280LE-LAT** (Ethernet/Internet + LTE(4G)/HSPA(3G)/2G)
- **LE2080-LAT** (LTE(4G)/HSPA(3G)/2G)
- **TL280LEX(R)** (LTE(4G))
- **LE2080X(R)** (LTE(4G))

## Features

- 128-bit AES encryption via cellular and Ethernet/Internet
  - NIST validation cert number 2645 (for models TL2803G(R)E/3G2080(R)E/TL280(R)E)
  - NIST validation cert number 4475 (for models TL280LE(R)/LE2080(R))
- Backup or primary cellular alarm communication.
- Automatically converts to 2G (EDGE/GPRS) if HSPA(3G) service is not available (2G not supported on European models only).
- Automatically switches from LTE to HSPA(3G) service if LTE service is not available.
- Ethernet LAN/WAN 10/100 BASE-T (TL2803G(R)E, TL280(R)E, TL280LE(R) only).
- Fully redundant Ethernet/Internet and cellular dual-path alarm communication (TL2803G(R)E, TL280LE(R) only).
- Full event reporting to the central station.
- Individual Internet and/or cellular periodic test transmission.
- Integrated call routing.
- Visual Verification (Requires Sur-Gard System 5 Receiver)
- Remote firmware upgrade capability of the communicator and panel firmware via Ethernet and/or cellular.
- Panel remote uploading/downloading support via cellular and Ethernet/Internet.
- PC-LINK connection.
- Programmable labels.
- SIA and Contact ID (CID) formats supported.
- Signal strength and trouble display LEDs.
- Supervision heartbeats sent via cellular and Ethernet/Internet.
- Third-party integration over cellular/IP. The product supports third-party application via serial (R-models only), cellular and Ethernet. Refer to third-party application documentation for more information.

**NOTE:** RS-232 connection is for supplementary user only and was not evaluated by UL/ULC.

## Technical Specifications

The TL2803G(R)E/TL280LE(R) are also suitable to be used with a compatible control unit listed for dual line security transmission when used in conjunction with a DACT or a Public Switched Data Network (PSDN) transmitter, where the PSDN provides the line security and is the primary line. In this mode, alarm signals are to be sent simultaneously over both communication methods.

## EN50131-1 Installation Requirements

For EN50131-1 compliant installations, the following programming options shall be set as described. Supervision Heartbeat (required for ATS4 and ATS5):

**NOTE:** The compatible receiver at ARC location shall have the supervision window programmed for 1800s (ATS4) or 180s (ATS5) for the primary communications path, which can be Ethernet receiver 1 or cellular receiver 1, depending on the product being installed.

- **[851][107]** Set to 0087h (135s Heartbeat) for Ethernet Receiver 1
  - **[851][207]** Set to 0087h (135s Heartbeat) for Cellular Receiver 1
  - **[851][100]** Options 1 and 2 shall be enabled if using Ethernet Receiver 1 as the primary path
  - **[851][200]** Options 1 and 2 shall be enabled if using Cellular Receiver 1 as the primary path
- Configuration of communication paths (all ATS classes)
- **[300][001]** select option 02 for auto routing (this will allow transmission of the events over all available communication paths in the system)
  - **[380]** enable option 5 (YES) for parallel transmission over all available communication paths (if redundant configuration is desired)
  - **[382]** enable option 5 (YES) to enable Alternate communicator
  - **[384]** enable the desired back-up configuration (receiver 2 back-up for receiver 1 or receiver 3 back-up for receiver 1).

## Ratings Compatibility

Table 7: Communicator Ratings

Model	3G2080(R)E/LE2080(R) Cellular only	TL280LE(R) / TL280LE-EU / TL2803G(R)LE2080(R) / LE2080-EU / 3G2080(R) / TL280(R)E Internet and Cellular	TL2803G(R)E/TL280LE(R) Internet and Cellular
<b>Power Supply Ratings</b>			
Input Voltage	10.8-12.5 VDC Power is supplied from the panel's PC-Link header or a PCL-422 module in remote cabinet installations. In remote cabinet installations, the PCL-422 module located with the communicator is powered by either an HSM2204 or an HSM2300. Refer to the PCL-422 installation instructions for details.		
<b>Current Consumption</b>			
Standby Current	90mA	100mA	120mA
Alarm (Transmitting) Current	400mA		
Operating Frequency	850MHz, 900MHz, 1800MHz, 1900MHz, 2100MHz (See Figure 1, 2, 3, 4, 5)		
Typical Antenna Gain	See page 70		
<b>Environmental Specifications</b>			
Operating Temperature	-10°C to 55°C (0°C to 49°C for UL/ULC)		
Humidity	5% ~ 93% relative humidity, non-condensing		
<b>Mechanical Specifications</b>			
Board Dimensions (mm)	100 × 150 × 15	100 × 150 × 15	100 × 150 × 15
Weight (grams) with bracket	310	300	320

Table 8: Compatible Receivers and Panels

Communicator	Receiver/Panel	Description
3G2080 (R) E LE2080 (R) LE2080X (R) TL280LEX (R) TL2803G (R) E TL280LE (R) TL280(R)E TL280LE-EU LE2080-EU TL280LE-LAT LE2080-LAT TL280LE-AU LE2080-AU	Receiver	<ul style="list-style-type: none"> <li>• Sur-Gard System I-IP Receiver, version 1.13+</li> <li>• Sur-Gard System II Receiver, version 2.10+</li> <li>• Sur-Gard SG-DRL3-IP, version 2.30+ (for Sur-Gard System III Receiver)</li> <li>• Sur-Gard SG-DRL4-IP version 1.20+ (for Sur-Gard System IV Receiver)</li> <li>• Sur-Gard SG-DRL5-IP version 1.00+ (for Sur-Gard System 5 Receiver)</li> </ul>
	Panel	<ul style="list-style-type: none"> <li>• HS2016 Version 1.0x – 1.5x</li> <li>• HS2016-4 Version 1.0x – 1.5x</li> <li>• HS2032 Version 1.0x – 1.5x</li> <li>• HS2064 Version 1.0x – 1.5x</li> <li>• HS2128 Version 1.0x – 1.5x</li> </ul>

**NOTE:** Enter [\*][8][Installer Code][900] at keypad to view the panel version number.

## Pre Installation Configuration

### Encryption

The communicator uses 128 Bit AES encryption. Encryption can only be enabled from the monitoring station receiver. Each receiver (Ethernet 1 and 2, Cellular 1 and 2) can independently have encryption enabled or disabled. When encryption is enabled, the central station will configure the device to encrypt communications the next time the communicator module sends communication to that receiver.

**NOTE:** Packets will start being encrypted only after the next event is sent to that receiver, or if the unit is restarted.

**Before leaving the installation site, the communicator TL2803(R)E / TL280LE(R) Ethernet line shall be connected via an approved (acceptable to the local authorities) Network Interface Device (NID). All wiring shall be performed according to the local electrical codes.**

## Communicator Installation Configuration

This alarm communicator shall be installed by skilled persons only (skilled person is defined as a person having the appropriate technical training and experience necessary to be aware of hazards to which that person may be exposed to in performing a task and can also take measures to minimize the risks to that person or other persons). The Communicator shall be installed and used within an environment that provides the pollution degree max 2, overvoltages category II, in non-hazardous, indoor locations only. This manual shall be used with the installation manual of the panel which is connected to the communicator. All instructions specified within the panel manual must be observed.

All the local rules imposed by local electrical codes shall be observed and respected during installation.

### Installing the Ethernet Cable (TL Models Only)

A Category 5 (CAT 5) Ethernet cable must be run from a source with Internet connectivity to the communicator module, inside the panel. The communicator end of the cable must be terminated with an RJ45 plug, which will connect to the communicator's RJ45 jack after the communicator is installed. All requirements for installation of CAT5 Ethernet cable must be observed for correct operation of the communicator, including, but not limited to, the following:

- Do NOT strip off cable sheathing more than required for proper termination.
- Do NOT kink/knot cable.
- Do NOT crush cable with cable ties.
- Do NOT untwist CAT5 pairs more than ½ in. (1.2cm).
- Do NOT splice cable.
- Do NOT bend cable at right angles or make any other sharp bends.
- Do NOT use CAT6 cable.

**NOTE:** CAT5 specification requires that any cable bend must have a minimum 2 in. (5 cm) bend radius. Maximum length of CAT 5 cable is 328 ft. (100 m).

## Inserting and Removing the SIM Card

1. Remove the front cover of the panel to access SIM holder.
  2. Remove power from the panel and disconnect the battery and telephone line.
  3. On the SIM card holder push gently to slide the cover downwards to **OPEN**. This will unlatch the SIM card holder on the top edge of the communicator PCB. (See **Figure 3**).
  4. Tilt the top of the SIM card holder downwards to access the SIM card.
- NOTE:** The SIM can be damaged by bending or scratching contacts. Use caution when handling SIM cards.
5. Insert or remove the SIM card, noting the orientation of the notches on the SIM card and the SIM card holder.
  6. When inserting a SIM card, insert the card in the proper orientation and gently push the SIM card holder down and slide the holder as indicated by the arrow on SIM holder, to **LOCK**.
  7. Reconnect the backup battery and telephone line, apply AC power to panel, and replace the panel cover.

## Running the RS-232 Cable (R models only)

When installing the communicator for use with 3rd party applications an RS-232 cable must be connected between the 3rd party device and the communicator module.

**NOTE:** Maximum cable length for RS-232 cable is 8 ft. (2.4 m).

Please refer to the installation manual for the 3rd party device for wiring instructions.

## Installing Communicator in Panel

### Installing the Communicator with HS20XX Panels

**NOTE:** Before installing the communicator or inserting/removing SIM, ensure that system power is off and telephone line is disconnected.

1. To assemble supplied mounting bracket, perform the following: (See **Figure 1**).
  - a. Remove the 4 white plastic standoffs from the bag provided with the communicator kit.
  - b. Insert the 4 standoffs through the back of the mounting bracket, into the holes at each corner. Ensure the antenna mounting tab is facing away from you.
  - c. Place the bracket on a flat, solid surface. Hold the communicator component side up and orient the 4 holes on the communicator with the 4 standoffs protruding from the bracket. Push the communicator firmly and evenly onto the standoffs until it is securely attached to the mounting bracket.
  - d. Remove the panel front cover.
  - e. Remove and discard the circular knockout located in the top-right section of the panel. The knockout will be used when connecting the antenna supplied.
  - f. Connect the 5" (12.7 cm) antenna cable supplied to the radio by passing the connector through the knockout to the communicator board. Push the antenna connector firmly into the socket on the cellular radio (see **Figure 3**).

Figure 1: Communicator Mounting Bracket

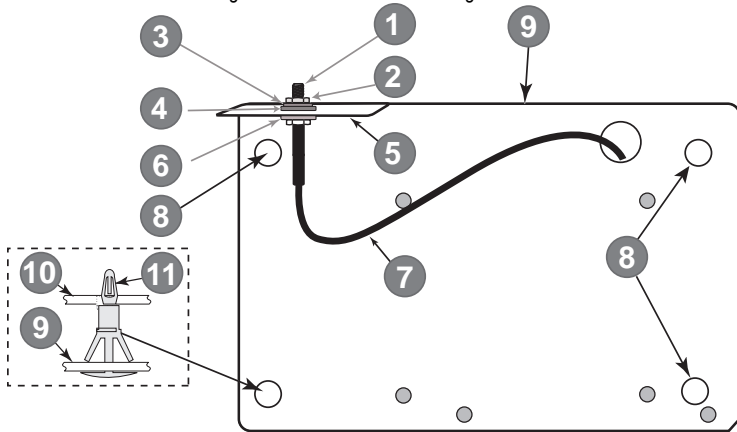

Item	Description
1	External Antenna Screw Thread
2	Brass Nut
3	Brass Washer
4	Nylon Washer (flat)
5	Antenna Mounting Tab
6	Nylon Washer with bushing (thicker flat washer)
7	Antenna Cable
8	Mounting Holes
9	Mounting Plate
10	Communicator Board
11	Stand Off

2. Install the Communicator into the panel:
  - a. Attach one end of the PC-LINK cable to the panel PCLINK\_2 header on the panel (red wire goes on the right-hand pin of the **panel** PCLINK\_2 header (see **Figure 3**)).
  - b. Insert the assembled communicator into the panel.  
**NOTE:** Ensure that the threaded antenna connection is visible through the knockout hole at the top right of the panel.
  - c. Place the nylon washer with bushing (thick flat washer) onto the threaded section of the antenna cable. Insert the threaded section through the antenna mounting knockout hole at top right of panel.
  - d. Place the second nylon washer (flat), followed by the brass washer and the brass nut, onto the threaded section of the cable, **outside** the panel. Tighten the assembly by hand only (finger tight only- do not over tighten the antenna assembly).
  - e. Locate the screw hole on the right side wall of the panel. See **Figure 2** "screw". Line up the assembled communicator with the right side wall of the panel and, using the screw provided, secure the mounting bracket to the panel.
  - f. Attach the other end of the PC-LINK cable to the communicator (red wire goes on the right-hand pin of the **communicator** PC-LINK header (See **Figure 3**)).
  - g. Using light pressure (finger tight only), attach the supplied white quad band whip antenna to the threaded antenna connector at top of the panel.

Figure 2: HS2016/2016-4/2032/2064/2128 Control Panel

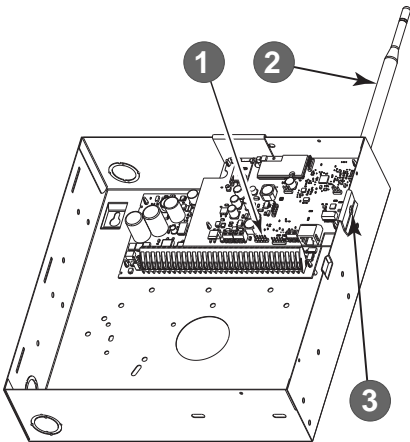

Item	Description
1	PC-Link Cable Connector
2	Quad Band Whip Antenna - Use light pressure to attach antenna <b>finger tight</b> only
3	Screw

**WARNING! - 3G2080(R)E/TL2803G(R)E/LE2080(R)/TL280LE(R) modules are power limited. Do not route any wiring over the circuit board. Maintain at least 1in. (25.4mm) separation between circuit board and wiring. A minimum of ¼ in. (7mm) separation must be maintained at all points between non-power limited wiring and power limited wiring.**

3. To wire the communicator to the panel, perform the following steps (See **Figure 3**):
  - a. Disconnect both AC power and battery connections from the panel, and disconnect telephone line.
  - b. Confirm that the SIM card is inserted in the holder and locked.
4. Install Network Cable (TL models only). Route the CAT 5 Ethernet cable through back of the panel and plug it into the communicator's RJ45 jack.
5. Install the RS-232 connections (R models only). If using the communicator with a 3rd party device, wire the connections as per Table 3.

**NOTE:** Before leaving the premises the Ethernet communication lines must first be connected to an approved type NID (acceptable to local authorities). All wiring shall be performed according to the local electrical codes.

Figure 3: Communicator Wiring Diagram

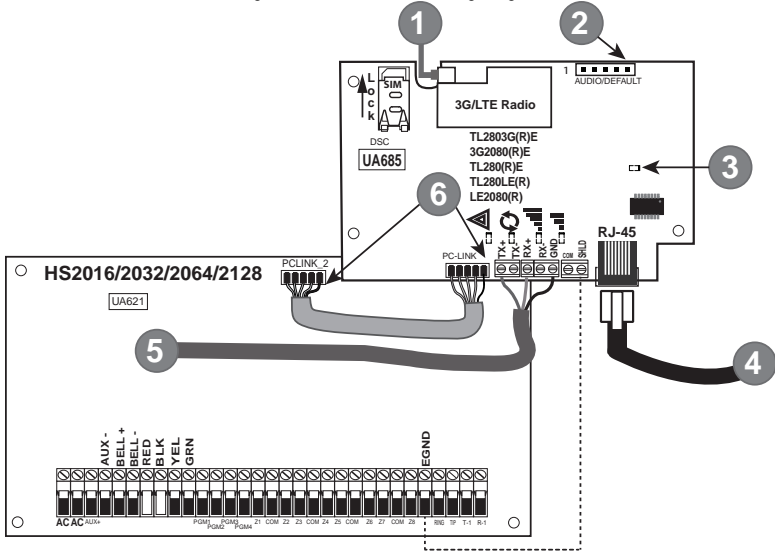

Item	Description
1	To External Antenna
2	AUDIO / DEFAULT Jumper pins 4 and 5 to reset
3	Network Link - Yellow
4	From NID use only CAT5 supervised maximum cable length 100m (328 feet)
5	RS-232 to third party device
6	RED Wire

**Input Ratings:**

- +10.8V ~ +12.5VDC
- 90mA 3G2080(R)E/120mA TL2803G(R)E standby
- 90mA 3G2080(R)E/LE2080(R)/LE2080-EU
- 120mA TL2803G(R)E/TL280LE(R)/TL280LE-EU
- 100mA TL280(R)E
- 400mA alarm

**DSC Panel minimum power requirements:**

- 16.5 VAC 40 VA transformer
- 12 VDC 7Ah battery

Table 9: RS-232 Connections

3rd Party Device	Communicator
TX (RED)*	RX+
Unused	RX-
RX (GRN)*	TX+
Unused	TX-
GND (BLK)*	GND

\*Wire colors based on the cable provided in the product box.

6. Perform the following steps for initial power on of the panel with communicator installed:

- Reconnect the AC power, telephone line, and battery + connector to the panel.  
(The communicator and panel will power up together).
- The communicator's red and yellow LEDs flash together while it initializes. The red and yellow LEDs will continue to flash until the communicator has successfully communicated to all programmed receivers.

**NOTE:** During radio reset, the two green LEDs will flash alternately.

**NOTE:** Initialization may take several minutes to complete. Do not continue to next step until the red and yellow LEDs have stopped flashing. (If only the yellow LED is flashing, there is a communicator trouble and the green LEDs are not valid for communicator placement test). Correct trouble indicated by flashes on yellow LED before continuing. See Table 8 for troubleshooting assistance.

7. Perform the communicator placement test below.
8. Mount the panel in final location indicated by placement test.

## Communicator Placement Test

### Cellular Communicator Models Only

To confirm that the cellular antenna location is suitable for radio operation, perform the placement test as follows:



**NOTE:** It might be necessary to relocate the panel or install an optional extension antenna during this procedure, if the radio signal strength is too low.

1. Confirm that the yellow LED on the communicator is not flashing. A flashing yellow LED indicates trouble on the communicator. See Table 8 to troubleshoot and correct the cause of this trouble before continuing to the next step.
2. Confirm that the strength of the radio signal on the yellow LED and the 2 green LEDs on the communicator meet or exceed the minimum signal level requirement. Minimum signal level: The yellow LED is **OFF** and the green LED 1 **■** (furthest from the yellow LED) is **ON** (not flashing) for the panel location to be acceptable. For interpretation of receiver strength on LEDs, refer to the table “**Radio Signal Strength**”.

### Cellular Signal Strength Display - LCD Keypad only

The cellular network signal strength can be checked on the keypad LCD screen by entering installer programming section [850]. The LCD will indicate the SIM card activation status followed by up to five bars of signal strength. This display will automatically update every three seconds. For the relationship between signal strength bars, CSQ level, and signal level in dBm, refer to “**Radio Signal Strength**”.

Table 10: Signal Strength Display

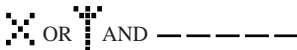
Description	Display
SIM card active and current signal strength	
SIM card inactive and current signal strength	
Radio not registered	

**NOTE:** If the required signal strength is too low with the panel in its current location, the panel must be relocated or an external antenna is required.

If required, the following cellular extension antenna kits are available to the installer:

- GS-15ANT/LTE-15ANT - 4.57m (15') internal antenna extension kit (suitable for interior mounting).
- GS-25ANT/LTE-25ANT - 7.62m (25') external antenna extension kit (suitable for interior/exterior mounting).
- GS-50ANT/LTE-50ANT - 15.24m(50') external antenna extension kit (suitable for interior/exterior mounting).

Specific instructions for the installation of the extension antenna are included with the kit. Observe all the electrical safety instructions regarding the installation of the antenna. All the wiring of the equipment shall be fully compliant with the local rules and regulations.

3. If required, install the antenna extension and perform the following steps to determine the best location for placement of the antenna:
  - a. Disconnect the white whip antenna from the panel.
  - b. Attach one end of the antenna extension cable to the threaded antenna connector on the panel and the other end to the external antenna.
4. Move the extension antenna to various locations while observing the two green LEDs on the panel.
  - a. Continue to reposition the extension antenna until it receives an acceptable (minimum one green LED ON solid) signal strength.
 

**NOTE:** Minimum strength is: **■** green LED 1 flashing and **△** yellow LED off. If green LED 1 is flashing, relocation should be considered.
  - b. Mount the supplied antenna extension bracket at the location that provides the best signal strength.
  - c. If necessary, relocate the panel to improve signal strength.
5. When final panel/antenna location is determined, continue at the **Initial Panel Programming** section.

**NOTE:** If the SIM card is not activated, placement test will indicate the signal strength of the nearest cellular tower.

**NOTE:** In between displaying signal strength, the signal strength LEDs will flash alternately if an inactive SIM card is used. The flashing indicates that the module is attempting to attach to the cellular network and will only last briefly.

## Initial Panel Programming

### Keypad Data Display

- **Section-Toggle Options:** The number is displayed when toggle is ON and the number is not displayed when toggle is OFF. (e.g., toggle options displays: [-3--6--]. Options 3 and 6 are ON, all others are OFF). Pressing keys 1 through 8 will alternately turn the toggle ON and OFF.
- **HEX/Decimal Data:** Values that are provided with two defaults, separated by a "/" character, use the format: hexadecimal followed by decimal equivalent (e.g., default [0BF5/3061]). Hexadecimal numbers are shown, with all leading zeroes, to the full field length defined for the number.

### Entering HEX values at keypad

To enter HEX values at the keypad, press the [\*] key before entering the HEX value. (e.g., to enter "C" at the keypad, press [\*][3])

### Entering ASCII Characters at keypad

1. Press [\*] and use scroll buttons [<] [>] to display "ASCII Entry" on the LCD screen.
2. Press [\*] to select ASCII entry mode.
3. Use the [<] [>] scroll keys to display the desired character and press [\*] to save and exit ASCII.
4. Repeat the steps above to enter another ASCII character.

### HS2016/2016-4/2032/2064/2128 Initial Programming

For detailed information, refer to panel manual section 'Alternate Communicator Set-up'. These sections must be programmed at the panel keypad. Enter [\*][8][Installer Code][Section Number]. Record any values that are modified from their default, in the appropriate worksheets for the panel or communicator.

1. In panel section [377] 'Communication Variables', subsection [002] 'Communication Delays', sub-subsection [1] 'Communication Delay', program 060 (seconds).
2. In panel section [382] 'Communicator Option 3' set option [5] ON.

**NOTE:** If this option is OFF, the yellow status LED on the communicator will indicate 'Panel Supervision Trouble' (2 flashes) and the unit can not be programmed via the PC-LINK cable.

### Activating the Communicator with C24 Communications

Installation of the 3G2080(R)E / LE2080(R) or TL2803G(R)E / TL280LE(R) in North America requires activation with C24 Communications in order to operate. Please contact the central station (C24 Communications Master Reseller) to confirm the required steps to activate / program the communicator.

All communicator options must be programmed via C24 Communications, except the following Ethernet options which can also be programmed using the keypad or DLS:

- [001] Ethernet IP Address
- [002] Ethernet IP Subnet Mask
- [003] Ethernet Gateway IP Address

**NOTE:** The SIM activation with the carrier can take several hours to complete. It is recommended the activation be completed prior to arrival on the customer site to avoid possible installation delays.

Once the SIM activation is complete, the communicator will automatically connect and download its programming from C24 Communications.

## SMS Command and Control

Certain functions can be performed on the alarm panel by remote using SMS text messages. In addition, the system sends SMS messages to confirm commands. SMS programming options are accessed through programming section [851]. The security system only responds to SMS messages sent from designated phone numbers (programmed in section [851]> [311]-[328]).

### SMS Commands

- Stay arm the system
- Away arm the system
- Night arm the system
- Disarm the system
- Activate command output 1
- Activate command output 2
- Activate command output 3
- Activate command output 4
- Deactivate command output 1
- Deactivate command output 2
- Deactivate command output 3
- Deactivate command output 4
- System status request
- Alarm memory request
- Zone bypass
- Zone unby pass

SMS text messages must be formatted as follows:

<function name><space><partition #><space><access code>

(e.g., Stay Arm partition 1 1234). Once the command is received and executed by the alarm system, a confirmation text message is received.

**NOTE:** For more information about SMS commands and control functions, refer to the Neo 1.1 User Manual.

## Communicator Status LEDs

The communicator has four on-board LED indicators. These include one yellow trouble LED, one red network connection status LED and two green signal strength LEDs. The LED meaning is described in this section.

### ▲ Yellow Trouble LED

This yellow LED will flash to indicate a trouble on the unit. The number of flashes indicates the type of trouble, refer to the table below for trouble conditions.

Table 11: Yellow Trouble Status LED

# of Flashes	Trouble	# of Flashes	Trouble
2	Panel Supervision Trouble	7	Receiver Not Available Trouble
4	Not Applicable	8	Receiver Supervision Trouble
5	Cellular Trouble	9	FTC Trouble
6	Ethernet Trouble	12	Module Configuration Trouble

**NOTE:** Only the highest priority trouble (2 flashes is the highest priority trouble) is indicated. When this trouble is restored, the next highest trouble is indicated, if present. This will continue until all troubles have been cleared (yellow LED is not flashing). When using an Ethernet + Cellular module, enable the Radio Not In Use option if no SIM card will be used with the device at the time of install. [851][010] Option 5 ON. This will suppress all cellular-related trouble conditions.

The following section describes the conditions associated with each trouble:

## Panel Supervision Trouble (2 Flashes)

This trouble occurs when communication between the communicator module and the panel fails. If the module can not communicate with the panel (e.g., loss of power to the panel) the communicator will send the 'Panel Absent Trouble' event message to the central station receiver. When communication returns, a 'Panel Absent Restore' event is sent by the communicator to the central station receiver. The reporting codes are ET0001 for trouble and ER0001 for restore. The Panel Absent event always uses the primary receiver account code when communicating to the central station.

**NOTE:** The panel supervision trouble/restore are internally generated events by the communicator. Trouble is generated if the communicator misses 6 polls. Trouble is restored on receipt of first poll from the panel.

## Cellular Trouble (5 Flashes)

This trouble occurs for any of the following 4 conditions:

1. **Radio Failure:** Trouble is indicated after 8 failed attempts to communicate with the cellular radio.
2. **SIM Failure:** Trouble is indicated after 10 failed attempts to communicate with the SIM.
3. **Cellular Network Trouble:** Trouble is indicated for loss of the registration to the network provider.
4. **Insufficient Signal Strength:** Trouble is indicated if calculated average signal strength is too low. (Both green LEDs are OFF). Trouble will clear when the calculated average signal strength is above minimum (i.e., > CSQ 5).

**NOTE:** If Option [851][005] Bit 8 is Off, CSQ less than or equal to 4 will not trigger Cellular Trouble

## Ethernet Trouble (6 Flashes)

This trouble occurs when an Ethernet link between the transmitter and the local switch or router is absent. This trouble will also be indicated if the unit fails to get Dynamic Host Control Protocol (DHCP) settings from the DHCP server (not active if Ethernet receivers are not programmed).

## Receiver Not Available (7 Flashes)

This trouble occurs if the unit is not able to successfully initialize with any of the programmed receivers. This trouble is also indicated if the cellular receiver APNs have not been programmed in sections [205] and [215].

## Receiver Supervision Trouble (8 Flashes)

This trouble occurs if the receiver supervision is enabled and communication between the communicator and the receiver fails. The trouble is indicated if any supervised communications path does not receive an acknowledgement to a heartbeat signal from the receiver.

## FTC Trouble (9 Flashes)

This trouble is indicated when the unit fails to communicate module events to the central station. Trouble is displayed after the unit has completed all communications attempts to all programmed receivers for events generated by the communicator.

## Module Configuration Trouble (12 Flashes)

This trouble is indicated when the system account code or the receiver account have not been programmed. Disabled receivers are excluded.

## △ Red Network Connection Status LED

### TL2803G(R)E / TL280LE(R)

**BLINKING:** Indicates communication in progress.

- Once quickly for outgoing Ethernet transmission.
- Twice quickly to indicate incoming Ethernet ACK/NACK.

**OFF:** This is the normal state of the red network connection status LED. There are no network connection issues present.

**ON:** There is a problem with the Ethernet or the cellular network connection. LED will be ON if any of the following occur: Ethernet cable is not connected, DHCP configuration times out, unit fails to get an IP address from the cellular network, or Cellular connection has been reset.

## ■ (Green LED 1) ■ (Green LED 2) and △ (Yellow LED) Signal Strength

**NOTE:** If the yellow LED is flashing, signal strength in table below is not valid.

See **Table 8** for troubleshooting flashing yellow LED.

Table 12: Radio Signal Strength

Signal Strength	CSQ Level	Yellow LED	Green LED 2	Green LED 1	Signal Level dBm	Action Required
Radio Not Ready	N/A	N/A	Alternate Flashing	Alternate Flashing	N/A	If this status persists and the yellow LED shows 5 flashes, confirm that the SIM card is active. Confirm cellular service is active in area. Relocate panel or install external antenna.
No Signal	0	ON	OFF	OFF	-113 or less	Check all antenna connections.
1 Bar	1 - 4	Flashing See Note	OFF	Flashing	-111 ~ -105	Relocate panel or install external antenna if yellow trouble LED shows five flashes.
2 Bars	5 - 6	OFF	OFF	Flashing	-103 ~ -101	
3 Bars	7 - 10	OFF	OFF	ON	-99 ~ -93	Location is OK. Cellular signal strength is greater than CSQ 7.
4 Bars	11 - 13	OFF	Flashing	ON	-91 ~ -87	
5 Bars	14 +	OFF	ON	ON	-85 and higher	

**NOTE:** The communicator will indicate cellular trouble (yellow LED = 5 flashes) if the calculated average CSQ Level is 4 or less.

#### Network Activity LEDs - Red and Green (TL2803G(R)E/TL280LE(R) only)

- **Ethernet Activity:** Red LED will blink quickly once for transmit, or twice for receive.
- **Cellular Activity:** Green LED 2 will blink quickly once for transmit, or twice for receive

## Communicator Reset/Update

### Factory Defaults Reset

Restore the programming options for the communicator to the factory settings by installing a hardware jumper. Perform the following steps to reset the communicator:

**NOTE:** A jumper is required on AUDIO/DEFAULT pins 4 and 5 to reset the hardware values.

1. Remove panel front cover.
2. Locate the AUDIO/DEFAULT 5 pin connector on the communicator board (see Figure 3).
3. Apply a jumper to short the hardware default pins 4 and 5.
4. Remove AC and DC power from the panel and then reapply power to the panel.
5. Wait until the two green LEDs on the communicator begin flashing rapidly.
6. Remove the jumper from the hardware default pins 4 and 5 (green LEDs will stop flashing).
7. Replace the panel cover.

**NOTE:** The communicator has now been reset to the factory default values.

### Firmware Update

The firmware of the device can be updated over cellular or Ethernet (remote or local updating):

- When the firmware update begins, all 4 LEDs are ON.
- During the firmware update process, the LEDs will cycle in a chaser pattern.
- During the firmware update process, the chaser pattern will briefly pause and resume again. This indicates firmware verification check has passed, and application update will begin.
- After a successful update, the unit will automatically restart.
- If the update fails, all 4 LEDs will flash ON, then OFF together at 1 second intervals.

**NOTE:** If the firmware update fails, restart the communicator by cycling power. For persistent update failures, contact technical support for assistance.

# Communicator Troubleshooting

**NOTE:** For additional details:

- Refer to section [983] for troubleshooting the firmware updates
- Refer to section [984] to view the trouble status
- Refer to section [985] for troubleshooting radio initialization

Table 13: Trouble Indications

Trouble indication	Trouble Indicator Digit	Possible Causes	Trouble Possible Solution
No Indication	N/A	No Power	<ul style="list-style-type: none"> <li>• Check the power connections between the panel and the communicator.</li> <li>• Confirm PC-LINK cable is properly installed between communicator and panel.</li> </ul>
Yellow LED – ON Solid	N/A	No Signal	<ul style="list-style-type: none"> <li>• Confirm that cellular network service is active in the area.</li> <li>• Ensure the antenna is securely connected to the radio. Check antenna stub cable is securely connected to the radio.</li> <li>• If an external antenna is used, ensure the antenna is securely screwed on to the antenna cable connector. Check external antenna for damage or open/short.</li> </ul>
Trouble LED – 2 Flashes	02	Panel Supervision Trouble	<ul style="list-style-type: none"> <li>• Check section [382] toggle option[5] is ON (Alternate Communicator Enabled).</li> <li>• Ensure the PC-LINK cable between the panel and communicator is connected properly (not reversed) and is securely in place.</li> </ul>
Yellow LED – 5 Flashes	05	Cellular Trouble	<ul style="list-style-type: none"> <li>• Confirm that cellular service is available and active in the area.</li> <li>• Check all antenna connections.</li> <li>• Ensure average radio signal strength is CSQ 5 or higher. (See Table 7).</li> <li>• Ensure the SIM card is properly inserted into the SIM card holder.</li> <li>• Ensure the SIM card has been activated (could take up to 24 hrs after install).</li> <li>• If this trouble persists, relocate the panel (and communicator) or install an external antenna extension kit.</li> </ul>
Yellow LED – 6 Flashes	06	Ethernet Trouble	<ul style="list-style-type: none"> <li>• Check with the ISP to confirm Internet service is active in the area.</li> <li>• Ensure the Ethernet cable is securely inserted into the RJ45 jack of the communicator and the hub/router/switch.</li> <li>• Check the link light on the hub/router/switch is ON. If link light is OFF, start the hub/router/switch.</li> <li>• If DHCP is used, ensure that the unit has an assigned IP address from the server. In Section [851] [992] verify a valid IP address is programmed. If not, contact the network administrator.</li> <li>• If problem persists, replace the Ethernet cable and RJ45 connector.</li> </ul>
Yellow LED – 7 Flashes	07	Receiver Not Available	<ul style="list-style-type: none"> <li>• Ensure that the Ethernet path has Internet connectivity.</li> <li>• If using a static IP address, confirm that the gateway and subnet mask are entered correctly.</li> <li>• If the network has a firewall, ensure the network has the programmed outgoing ports open (default UDP port 3060 and port 3065).</li> <li>• Ensure that all the receivers are programmed for DHCP or have the proper IP address and port number.</li> <li>• Ensure the cellular receiver APNs have been programmed with the access point name provided by the cellular provider.</li> <li>• If Common Mode is used, and only one path is initialized while the other path is not successful, generate a manual test transmission over both paths or power cycle the communicator to recover the 'Receiver Not Available' trouble.</li> </ul>

Trouble indication	Trouble Indicator Digit	Possible Causes	Trouble Possible Solution
Yellow LED – 8 Flashes	08	Receiver Supervision Trouble	<ul style="list-style-type: none"> <li>This trouble is indicated when supervision is enabled and the unit is not able to successfully communicate with the receiver.</li> <li>If this trouble persists, contact the central station.</li> </ul>
Yellow LED - 9 Flashes	09	FTC Trouble	<ul style="list-style-type: none"> <li>The unit has exhausted all communications attempts to all programmed receivers for events generated by the communicator.</li> <li>Restart the system, if trouble persists, contact the dealer.</li> </ul>
Yellow LED – 12 Flashes	0C	Module Configuration Trouble	<ul style="list-style-type: none"> <li>This indication appears when section [021] system account code or sections [101], [111], [201], and [211] receiver account code have not been programmed. Ensure that a valid account code has been entered in these sections.</li> </ul>
All LEDs flashing together	N/A	Boot Loader Failed	<ul style="list-style-type: none"> <li>Disconnect power, then reconnect power to the communicator module.</li> </ul>
Red and Yellow LEDs flashing together	N/A	Initialization Sequence	<ul style="list-style-type: none"> <li>The unit is still initializing, please wait while the unit gets its programming and establishes a connection to all programmed receivers.</li> </ul> <p><b>NOTE:</b> This process may take several minutes to complete.</p>
Only Green LEDs flashing	N/A	Hardware Default Jumper	<ul style="list-style-type: none"> <li>The hardware default jumper is installed and must be removed. See Figure 3.</li> </ul>
Green LEDs alternating	N/A	Radio Reset or Radio Initialization	<ul style="list-style-type: none"> <li>If this status persists and the yellow LED shows 5 flashes, confirm that the SIM card is active.</li> </ul>

## Ethernet/Cellular Programming Options

The programming sections described in this document can be viewed at the keypad LCD. To start programming, enter: **[\*][8][installer code][851][section number]**, where section number is the 3-digit section number referenced in this section. The programming worksheets at the end of this document can be used to record the new values when programming changes have been made from the default values. Installers may review/record programming options at the panel keypad.

### System Options

#### [001] Ethernet IP Address

Default (000.000.000.000)

Enter the IP address of the communicator. Ensure that the IP address is unique to the communicator on the local network. Format is 4 fields, each field is a 3 digit decimal number. Valid range: 000-255. If an IP address is programmed in this section, the unit will operate with static IP (DHCP disabled). Sections [002] and [003] must also be programmed when using static IP addresses.

**NOTE:** Default for this section is Dynamic Host Configuration Protocol (DHCP) enabled. When enabled, the DHCP server will set values for: IP address [001], subnet mask [002], and gateway [003]. Programming an IP address in this section will disable DHCP (Static IP).

#### [002] Ethernet IP Subnet Mask

Default (255.255.255.000)

Enter the Ethernet IP subnet mask of the communicator. Format is 4 fields, each field is 3 digits. Valid range: 000-255.

**NOTE:** If DHCP is enabled, the DHCP server will assign the subnet mask for this section and the programmed value will be ignored.

#### [003] Ethernet Gateway IP Address

Default (000.000.000.000)

Enter the Ethernet gateway IP address of the communicator. The gateway IP address is required when a router is used on the local network to reach the destination IP address specified in section [001]. Format is 4 fields, each field is a 3-digit decimal number. Valid range: 000-255.

**NOTE:** If DHCP is enabled, the DHCP server will assign the gateway IP address for this section and the programmed value will be ignored.

#### [005] System Toggle Options

##### [3] Supervision Type Default (OFF)

**ON:** Heartbeat 1 (commercial supervision). This supervision type is suitable for applications where swap detection is required on the supervisory packet.

**OFF:** Heartbeat 2 (residential supervision). This supervision type is suitable for applications where supervision of the communication path to the receiver is required (no swap detection).

**NOTE:** Commercial supervision is more data intensive than residential supervision and should only be used when required to meet the approval for the installation.

##### [4] Primary Path Default (OFF) - TL2803G(R)E/TL280LE(R); (ON) - 3G2080(R)E/LE2080(R)

**ON:** Cellular channel is the primary path. Ethernet channel is the secondary path, if it exists.

**OFF:** Ethernet channel is the primary path in a dual communicator. Cellular channel is the secondary path.

##### [5] For Future Use

##### [6] Remote Firmware Upgrade Default (ON)

**ON:** The communicator module firmware can be remotely upgraded using the Ethernet/ Cellular paths.

**OFF:** The communicator module firmware can not be remotely upgraded. Local firmware upgrade is still possible.

##### [7] Alternate Test Transmissions Default (OFF).

**ON:** When the periodic test transmission interval occurs, the test transmission will alternate between being sent to the primary and secondary receivers with each test transmission interval.

**OFF:** When the periodic test transmission interval occurs, the test transmission will be sent to the programmed receivers, based on the settings of the periodic test transmission reporting codes.

##### [8] Cellular Low Signal Trouble. Default (OFF)

This option masks the low signal trouble from generating cellular trouble.

**ON:** A cellular trouble event is generated when the radio signal level falls below threshold level (average CSQ level is 4 or less).

**OFF:** A cellular trouble event is not generated when the radio signal level falls below threshold level (average CSQ level is 4 or less).

## [006] System Toggle Options 2

### [1]- IPv6 control

ON - IPv4v6 Enabled. This option may be required by certain network providers. It is enabled at default in LTE communicators for LATAM, Europe and Australia

Off - IPv4 Only. This option is disabled at default in North American LTE communicators.

**[5] - Radio Not In Use (v5.6+)**ON - Radio Not In Use - The cellular radio will be disabled, preventing any trouble conditions related to cellular from being indicated. This option applies to LATAM, European and Australian communicators and has no effect in NA products. Enable this if no SIM card is being used with the communicator.

Off - Radio in Use

**[7] DLS Over Cellular.** Default (ON).

**ON:** DLS is enabled on the cellular path.

**OFF:** DLS is disabled on the cellular path.

**NOTE:** Program this toggle as OFF to prevent DLS from using the cellular path.

**NOTE:** If this toggle is OFF, DLS sessions will occur on the Ethernet path only, regardless of the primary path set in section [005] toggle option [4]. If it is ON, the communicator will connect to the primary path first for DLS and if the session fails, the secondary path will be used.

**[8] Network Trouble Suppression.** Default (OFF).

**ON:** GSM/Ethernet/Supervisory troubles and restore signals follow delay timer as programmed in section [226].

**OFF:** GSM/Ethernet/Supervisory troubles and restore signals are sent immediately.

## [007] Primary Ethernet DNS IP

Default (000.000.000.000)

Enter the IP address for DNS server 1. Format is 4 fields, each field is a 3-digit decimal. Valid range: 000-255.

**NOTE:** If no value is programmed and DHCP is used, the DHCP server will configure the address. If an address is programmed and DHCP is used, the programmed address will be used instead of the DHCP address.

## [008] Backup Ethernet DNS IP

Default (000.000.000.000)

Enter the IP address for DNS server 2. Format is 4 fields, each field is a 3-digit decimal. Valid range: 000-255.

**NOTE:** If no value is programmed and DHCP is used, the DHCP server will assign this value. If an address is programmed and DHCP is used, the programmed address will be used instead of the DHCP address.

## [009] Language

Default (01)

Opt	Language	Opt	Language	Opt	Language	Opt	Language
01	English	09	Finnish	17	Not Used	25	Ukrainian
02	Spanish	10	German	18	Croatian	26	Slovakian
03	Portuguese	11	Swedish	19	Hungarian	27	Serbian
04	French	12	Norwegian	20	Romanian	28	Estonian
05	Italian	13	Danish	21	Russian	29	Slovenian
06	Dutch	14	Hebrew	22	Bulgarian	30-99	Reserved
07	Polish	15	Greek	23	Latvian		
08	Czech	16	Turkish	24	Lithuanian		

**NOTE:** Programming this section with an invalid language will default to English (01).

**NOTE:** After programming this section, perform a Default Language in section [999][11] to have programmable labels available in the selected language.

## Programming Options

### [010] System Toggle Options 3

**[1] 2-Way Audio Over Cellular.** Default (OFF)

**ON:** 2-Way Audio Over Cellular is enabled.

**OFF:** 2-Way Audio Over Cellular is disabled.

**[2] Visual Verification.** Default (OFF)

**ON:** Visual verification is enabled.

**OFF:** Visual verification is disabled.

**[3] Video On Demand.** Default (OFF)

**ON:** Video On Demand is enabled.

**OFF:** Video On Demand is disabled.

**[4] Receiver Group.** Default (OFF)

**ON:** Receiver Group is enabled.

**OFF:** Receiver Group is disabled.

**NOTE:** Enable this option when visual verification needs to be sent to more than one receiver.

**NOTE:** Auto-Routing must be enabled in section [300] of the Neo panel.

**[5] - [8] Reserved.**

**[011] Installer Code**

Default (CAFE)

Program the installer code for the communicator module. The installer code will be required when programming the communicator module. Valid range: 0000 - FFFF.

**[012] DLS Incoming Port**

Default (0BF6/3062)

The DLS incoming local port (listening port) is the port DLS IV will use when connecting to the communicator. If a router or gateway is used, it must be programmed with a transmission control protocol (TCP) port forward for this port to the communicator module IP address. Valid range: 0000 - FFFF.

### [013] DLS Outgoing Port

Default (0BFA/3066)

The DLS outgoing port is used for outgoing sessions to DLS after an SMS request has been sent to the communicator. Use this section to set the value of the local outgoing port. The value must be changed if the communicator is located behind a firewall and must be assigned a particular port number, as determined by the network administrator. In most cases, changing the default value or configuring the firewall with this port is not required.

Valid range: 0000-FFFF.

**NOTE:** If section [006] toggle option [7] is ON, DLS will use the primary path. If section [006] toggle option [7] is OFF, DLS will use the Ethernet path, if available.

### [015] DLS Call-Up IP

Default (000.000.000.000)

### [016] DLS Call-Up Port

Default (0000)

### [018] Receiver Group Programming

Default (0000)

Program this section when visual verification signals need to be sent to multiple central station receivers. The communicator will attempt to retransmit signals to an individual receiver if there is a problem sending signals to that receiver. A failure to communicate (FTC) trouble is generated by the communicator if a receiver did not acknowledge the alarm signal. The communicator will indicate the trouble on the control panel keypad as a 'Receiver X FTC Trouble'.

Any two receiver paths can be assigned to the receiver group, but it is recommended to use Ethernet Receiver 1 and Cellular Receiver 1 in this configuration so a single point of failure doesn't disable both transmission paths.

Panel events are still acknowledged when there is an FTC trouble on one of the receivers. The trouble will continue to display until the communicator is able to successfully send signals to both paths.

**NOTE:** The Receiver Group must be enabled in section [851][010] Option 4.

**NOTE:** Auto-Routing must be enabled in section [300] of the PowerSeries Neo panel.

01 = Ethernet Receiver 1

02 = Ethernet Receiver 2

03 = Cellular Receiver 1

04 = Cellular Receiver 2

(e.g. 0103 = Receiver group programming for Ethernet Receiver 1 and Cellular Receiver 1.)

An entry of 00 or FF denotes no receiver or disabled.

### [019] - Network Profile (TL280LE-AU and LE2080-AU v5.6+Only)

This setting determines which network profile the radio will be configured to use. Changing this setting modifies a variety of non-programmable options required by networks in Australia and New Zealand.

01 = Telstra

02 = Vodafone

03 = KDDI

04 = Softbank

05 = NTT Docomo (default)

06 = Spark

Note: The Telstra profile should be used with Optus SIM cards.

**[020] Time Zone**

Default (00)

Please refer to the panel manual section 'Real-Time Clock' for more details. Use Column 2 (Offset Hours) to find the local Time Zone. Record the two-digit HEX value from Column 1 (HEX Value) on the same row. Program this HEX value for the Time Zone. Valid range is 00 - FF.

Table 14: World Wide Time Zone

HEX Value	Offset Hours	Standard Abbreviation	Location
01	-12	BIT	Baker Island Time
05	-11	SST	Somoa Standard Time
09	-10	HAST	Hawaii-Aleutian Standard Time
0B	-9.5	MIT	Marquesas Island Time
0D	-9	AKST	Alaska Standard Time
11	-8	PST	Pacific Standard Time
15	-7	MST	Mountain Standard Time
19	-6	CST	Central Standard Time
1D	-5	EST	Eastern Standard Time
1F	-4.5	VST	Venezuela Standard Time
21	-4	AST	Atlantic Standard Time
23	-3.5	NST	Newfoundland Standard Time
25	-3	ART	Argentina Time
29	-2	BEST	Brazil Eastern Standard Time
2D	-1	CVT	Cape Verde Time
31	0	GMT	Greenwich Mean Time (UTC)
35	1	CET	Central European Time
39	2	SAST	South Africa Standard Time
3D	3	AST	Arabic Standard Time
3F	3.5	IRST	Iran Standard Time
41	4	GST	Gulf Standard Time
43	4.5	AFT	Afghanistan Time
45	5	PKT	Pakistan Time
47	5.5	IST	Indian Standard Time
48	5.75	NPT	Nepal Time
49	6	VOST	Vostok Time
4B	6.5	MMT	Myanmar Time
4D	7	BDT	Bangladesh Standard Time
51	8	CST	China Standard Time
52	8.25	APO	Apo Island Time

HEX Value	Offset Hours	Standard Abbreviation	Location
54	8.75	ACWST	Australian Central Western Standard Time
55	9	KST	Korea Standard Time
57	9.5	ACST	Australian Central Standard Time
59	10	AEST	Australian Eastern Standard Time
5B	10.5	LHST	Lord Howe Standard Time
5D	11	VUT	Vanuatu Time
5F	11.5	NFT	Norfolk Island Time
61	12	NZST	New Zealand Standard Time
64	12.75	CHAST	Chatham Island Standard Time
65	13	TOT	Tonga Time
69	14	LINT	Line Island Time
70-FF	N/A	N/A	N/A

### [021] Account Code

Default (FFFFFF)

The account code is included when transmitting any events generated by the communicator. (e.g., panel absent trouble). It is recommended that the account code be the same as the control panel account number. Valid range: 000001-FFFFFF. If 4-digit account codes are needed, the two lowest digits must be programmed as FF (e.g., Account 1234 is programmed as:1234FF).

**NOTE:** Programming this section with all 0's or F's will cause a module configuration trouble.

**NOTE:** This section shall sync with panel option [310] with PowerSeries Neo panels version 1.00 or higher.

### [022] Communications Format

Default (04)

Program 03 for Contact ID (CID). Program 04 for SIA. The module can be configured to send Events in SIA or CID format. The SIA communication format follows the level 2 specifications of the SIA Digital Communication Standard - October 1997. This format will send the account code along with its data transmission. The transmission will look similar to the following at the receiver.

**NOTE:** This section shall sync with PowerSeries Neo panels version 1.00 or higher.

Example:

**ri0 ET001** where: **N** = New Event; **ri0** = Partition/Area identifier; **ET** = Panel Absent Trouble; **001** = Zone 001.

## Communications Reporting Codes

Table 15: Communications Reporting Codes

Event	SIA Identifier	SIA Reporting Code	CID Qualifier	CID Event Code	CID Reporting Code	CID User/Zone
[023] Panel Absent Trouble	ET	0001	1	3	55	001
[024] Panel Absent Trouble Restore	ER	0001	3	3	55	001
[026] Ethernet 1 Test Transmission	RP	0001	1	6	A3	951
[027] Ethernet 2 Test Transmission	RP	0002	1	6	A3	952
[028] Cellular 1 Test Transmission	RP	0003	1	6	A3	955
[029] Cellular 2 Test Transmission	RP	0004	1	6	A3	956
[030] FTC Restore	YK	0001	3	3	54	001

### [023] Panel Absent Trouble

Default (FF)

Program 00 to disable this event or FF to enable. This event will occur when communications with the panel have been lost for more than 60 seconds.

### [024] Panel Absent Trouble Restore

Default (FF)

Program 00 to disable this event or FF to enable. This event will occur when communications with the control panel have resumed.

### [025] Radio Activation Restore

Default (FF)

Program 00 to disable this event or FF to enable. This event will occur in North American cellular communicators when the unit has been programmed by Connect24.

## System Test Options

### Test Transmissions to Primary Receiver, with Backup to Secondary Receiver:

Set Ethernet section [026] to (FF); [027] to (00). Set cellular section [028] to (FF); [029] to (00).

- If the test transmission fails to the primary receiver it will back up to the secondary receiver.
- If the test transmission fails to the secondary receiver an FTC trouble will be generated.

### Test Transmission Unique to Primary and Secondary Receivers:

Set Ethernet section [026] to (FF); [027] to (FF). Set cellular section [028] to (FF); [029] to (FF).

- The module will send periodic test transmissions to each receiver independently, with no backups.
- If the test transmission fails to any of the programmed receivers, an FTC trouble will be generated.

### Alternate Test Transmission:

Alternate test transmission can be enabled or disabled in section [005] toggle option [7].

### Alternate Test Transmission with Backup Receivers:

Set Ethernet section [026] to (FF); [027] to (00). Set cellular section [028] to (FF); [029] to (00).

Interval 1:

- If the test transmission fails to the primary receiver, it will back up to the secondary receiver.
- If the test transmission fails to the secondary receiver, an FTC trouble will be generated.

Interval 2:

- If the test transmission fails to the secondary receiver, it will back up to the primary receiver.
- If the test transmission fails to the primary receiver, an FTC trouble will be generated.

### Test Transmission Unique to Primary and Secondary Receivers:

Set Ethernet section [026] to (FF); [027] to (FF). Set cellular section [028] to (FF); [029] to (FF).

Interval 1:

- The module will send periodic test transmissions to primary receivers (Ethernet primary and cellular primary) independently, with no backups.
- If the test transmission fails to any of the programmed primary receivers, an FTC trouble will be generated

Interval 2:

The module will send periodic test transmissions to secondary receivers (Ethernet secondary and cellular secondary) independently, with no backups.

- If the test transmission fails to any of the programmed secondary receivers, an FTC trouble will be generated

### [026] Ethernet 1 Test Transmission

Default (FF)

Program 00 to disable this event transmission or FF to enable. See System Test Options (previous page) for details on settings.

### [027] Ethernet 2 Test Transmission

Default (00)

Program 00 to disable this event transmission or FF to enable. See System Test Options (previous page) for details on settings.

### [028] Cellular 1 Test Transmission

Default (FF)

Program 00 to disable this event transmission or FF to enable. See System Test Options (previous page) for details on settings.

### [029] Cellular 2 Test Transmission

Default (00)

Program 00 to disable this event transmission or FF to enable. See System Test Options (previous page) for details on settings.

**NOTE:** The time interval (in minutes) between periodic tests is programmed in section [125] (Ethernet) and section [225] (cellular).

### [030] FTC Restore

Default (FF)

Program 00 to disable this event transmission or FF to enable. This event will occur when an FTC Trouble on the system restores.

### [033] Communicator Firmware Update Begin

Default (FF)

Program 00 to disable this event transmission or FF to enable. This event will occur when a communicator firmware update begins.

### [034] Communicator Firmware Update Success

Default (FF)

Program 00 to disable this event transmission or FF to enable. This event will occur when a communicator firmware update has completed successfully.

Table 16: System Firmware Update Failure

Event	SIA Identifier	SIA ReportingCode	CID Qualifier	CID Event Code	CID Reporting Code	CID User/Zone
[037] System FW Update Fail	LU	0000	1	9	04	003

**NOTE:** The communicator will report 'System Update Fail' only if the panel goes offline after a remote firmware update session has started.

### [095] SA Incoming Local Port

Default (0C14/3092)

### [096] SA Outgoing Local Port

Default (0C14/3093)

### [097] SA Call Up IP

Default (000.000.000.000)

### [098] SA Call Up Port

Default (0000)

### [099] SA Password

Default (FFFFFFFF)

## Ethernet Receiver 1 Options

### [100] Ethernet Receiver 1 Enabled

**Option 1:** Default ON

**ON:** Ethernet receiver 1 is enabled.

**OFF:** Ethernet receiver 1 is disabled.

**Option 2:** Ethernet receiver 1 Supervision Enabled – Default OFF

**ON:** Ethernet receiver 1 is supervised and heartbeats are sent to Ethernet Receiver 1 based on the supervision interval programmed in section [107].

**OFF:** Ethernet receiver 1 is not supervised. When it is disabled, a commercial heartbeat is sent to the receiver once per hour, regardless of the supervision type selected, residential or commercial.

### [101] Ethernet Receiver 1 Account Code

Default (0000000000)

The account code is used by the central station to distinguish between transmitters. This account code is used when transmitting heartbeat signals to the central station receiver. Signals received from the panel will use the control panel account number. Valid range: 0000000001-FFFFFFFFFE. Programming all 0's or all F's will cause a module configuration trouble.

**NOTE:** If Ethernet receiver 1 and cellular receiver 1 are programmed as the same receiver (IP and port number are identical), Ethernet receiver 1 account code will be used.

### **[102] Ethernet Receiver 1 DNIS**

Default (000000)

The Dialed Number Information Service (DNIS) is used in addition to the account code to identify the communicator module at the central station. Valid range: 000000 - 099999. Value is entered as a leading 0 followed by the 5-digit DNIS.

### **[103] Ethernet Receiver 1 Address**

Default (127.000.000.001)

The default address enables the communicator to operate in Unattended mode.

Unattended mode is used when a receiver is not available and the unit is required to perform DLS sessions. Typically used where the customer programs the control panel daily due to access control and still wants to receive alarms without buying extra hardware (receiver) or software.

**NOTE:** When a valid IP address has been programmed, Ethernet receiver 1 is enabled and will communicate events over the Ethernet channel.

Ethernet receiver 1 and cellular receiver 1 may be configured to communicate to the same central station receiver. To configure the device to operate using this common receiver mode functionality, program Ethernet receiver 1 and cellular receiver 1, IP address and port number with identical values.

**NOTE:** When operating in common receiver mode, Ethernet receiver 1 account code will be used for Ethernet and cellular.

### **[104] Ethernet Receiver 1 UDP Remote Port**

Default (0BF5/3061)

This section determines the UDP remote port of Ethernet receiver 1. Valid range: 0000 - FFFF.

### **[105] Ethernet Receiver 1 UDP Local Port**

Default (0BF4/3060)

Use this section to set the value of the UDP local outgoing port. Set the value of this port when the installation is located behind a firewall and must be assigned a particular port number as determined by the central station system administrator. Valid range: 0000 - FFFF.

### **[106] Ethernet Receiver 1 Domain Name**

Default ( )

Enter the domain name as 32 ASCII characters.

### **[107] Ethernet Receiver 1 Supervision Interval**

Default (0087/135 seconds)

The supervision interval is only valid if the supervision has been enabled for Ethernet receiver 1 in section [100]. The receiver supervision interval determines the delay, in seconds, between each heartbeat signal sent to the central station receiver. If the interval programmed is less than 10 seconds (000A) then supervision is disabled. The valid range for this section is 000A - FFFF seconds.

**NOTE:** This supervision interval programmed in the central station receiver must be 65s longer than the interval programmed in the communicator to ensure stable operation.

## **Ethernet Receiver 2 Options**

### **[110] Ethernet Receiver: Options**

**Option 1:** Ethernet Receiver 1 Enabled – Default ON/OFF

**ON:** Ethernet receiver 1 is enabled.

**OFF:** Ethernet receiver 1 is disabled.

**Option 2:** Ethernet Receiver 2 Supervision Enabled – Default OFF

**ON:** Ethernet receiver 2 is supervised and heartbeats are sent to Ethernet receiver 2 based on the supervision interval programmed in section [117].

**OFF:** Ethernet receiver 2 is not supervised. When disabled, a commercial heartbeat is sent to the receiver once per hour, regardless of the supervision type selected, residential or commercial.

### **[111] Ethernet Receiver 2 Account Code**

Default (0000000000)

The account code is used by the central station to distinguish between transmitters. The account code is used when transmitting heartbeat signals to the central station receiver. Signals received from the control panel will use the control panel account number. Valid range: 0000000001- FFFFFFFF. Programming all 0's or all F's will cause a module configuration trouble (yellow LED=12 flashes).

**NOTE:** If both Ethernet receiver 2 and cellular receiver 2 are the same receiver (IP and port number are identical), Ethernet receiver 2 account will be used for Ethernet and cellular.

### [112] Ethernet Receiver 2 DNIS

Default (000000)

The DNIS is used in addition to the account code to identify the communicator module at the central station. Valid range: 000000 - 099999. Value is entered as leading 0 followed by the 5-digit DNIS.

### [113] Ethernet Receiver 2 Address

Default (000.000.000.000)

Programming the Ethernet receiver 2 IP address with 000.000.000.000 will disable Ethernet.

Enter the Ethernet receiver 2 IP address. This address will be provided by the central station system administrator. Format is 4 fields, each field is a 3-digit decimal. Valid range: 000-255.

**NOTE:** When a valid IP address has been programmed, Ethernet receiver 2 is enabled and will communicate events over the Ethernet channel.

Ethernet receiver 2 and cellular receiver 2 may be configured to communicate to the same central station receiver.

To configure the device to operate using this common receiver mode functionality, program the Ethernet receiver 2 and cellular receiver 2 IP address and port number with the same values. When operating in common receiver mode the Ethernet receiver 2 account code will be used for communications over Ethernet and cellular.

**NOTE:** Do not program Ethernet receiver 1 and Ethernet receiver 2 to communicate to same receiver.

### [114] Ethernet Receiver 2 UDP Remote Port

Default (0BF5/3061)

This section is used to program the port number used by Ethernet receiver 2. Set the value of this port when the installation is located behind a firewall, and must be assigned a particular port number as determined by the central station system administrator. Valid range: 0000 - FFFF.

**NOTE:** Do not program Ethernet receiver 1 and Ethernet receiver 2 port with the same value.

### [115] Ethernet Receiver 2 UDP Local Port

Default (0BF9/3065)

This section is used to program the value of the local outgoing port. Use this option when the installation is located behind a firewall and must be assigned a particular port number as determined by the network administrator. Valid range: 0000 - FFFF.

**NOTE:** Do not program Ethernet receiver 1 and Ethernet receiver 2 port with the same value.

### [116] Ethernet Receiver 2 Domain Name

Default ( )

Enter the Domain Name as 32 character ASCII.

### [117] Ethernet Receiver 2 Supervision Interval

Default (0087/135 seconds)

The supervision interval is only valid when supervision has been enabled for Ethernet receiver 2 in section [110]. The receiver supervision interval determines the delay, in seconds, between each heartbeat signal sent to the central station receiver. If the interval programmed is less than 10 seconds (000A) then supervision is disabled. The valid range for this section is 000A - FFFF seconds.

**NOTE:** The supervision interval programmed in the central station receiver must be 65s longer than the interval programmed in the communicator to ensure stable operation.

## Ethernet Options

### [124] Ethernet Test Transmission Time

Default (9999)

Enter a 4-digit number (0000-2359) using the 24-hour clock format (HHMM) to set the test transmission time of day. Valid range: 00 - 23 hours (HH) and 00 - 59 minutes (MM). Programming a value of 9999 will disable the test transmission time.

**NOTE:** The internal date and time will automatically be programmed when the unit communicates with the primary receiver.

### [125] Ethernet Test Transmission Cycle

Default (000000)

This value represents the interval between test transmissions, in minutes. Valid range: 000000 - 999999 minutes. Once the unit has sent the initial periodic test transmission, all future test transmissions will be offset by the programmed number of minutes. See sections [026] - [029].

Table 17: Ethernet Test Transmission Interval

Test Transmission Interval	Daily	Weekly	Monthly
Programmed Minutes	001440	010080	043200

**NOTE:** Minimum value is 000005 minutes. Programming an interval that is less than 5 minutes will disable test transmission.

## Cellular Receiver 1 Options

### [200] Cellular Receiver 1 Options

**Option 1:** Cellular Receiver 1 Enabled - Default ON/OFF

**ON:** Cellular receiver 1 is enabled.

**OFF:** Cellular receiver 1 is disabled.

**Option 2:** Cellular Receiver 1 Supervision Enabled - Default OFF

**ON:** Cellular receiver 1 is supervised and heartbeats are sent to cellular receiver 1 based on the supervision interval programmed in section [207].

**OFF:** Cellular receiver 1 is not supervised.

### [201] Cellular Receiver 1 Account Code

Default (0000000000)

The account code is used by the central station to distinguish between transmitters. This account code is used when transmitting heartbeat signals to the central station receiver. Signals received from the control panel will use the control panel account number. Valid range: 0000000001 - FFFFFFFFE. Programming all 0's or all F's will cause a module configuration trouble (yellow LED = 12 flashes).

### [202] Cellular Receiver 1 DNIS

Default (000000)

The DNIS is used in addition to the account code to identify the communicator module at the central station. Valid range: 000000 - 099999. Values are entered as a leading 0 followed by the 5-digit DNIS.

### [203] Cellular Receiver 1 Address

Default (000.000.000.000)

Enter the cellular receiver 1 IP address. This information will be provided by the central station system administrator. Each 3-digit segment of the address must be within a valid range of 000-255.

**NOTE:** When a valid IP address has been entered, the cellular receiver is enabled and will communicate events over the cellular channel.

### [204] Cellular Receiver 1 Port

Default (0BF5/3061)

This section determines the port used by cellular receiver 1. Change the default value of this port when the installation is located behind a firewall and must be assigned a particular port number as determined by the central station system administrator. Valid range: 0000 - FFFF.

**NOTE:** Programming this section with 0000 will disable the receiver.

### [205] Cellular Receiver 1 APN

Default ( )

The Access Point Name (APN) determines the cellular network that the communicator will connect to. This information is available from the network carrier. Program this section as 32 ASCII characters.

**NOTE:** When a SIM card with a custom APN is used, the unit will not have access to the Internet. DLS and remote flash can still be done if section [221] is programmed with a valid public APN.

### [206] Cellular Receiver 1 Domain Name

Default ( )

Enter the Domain Name as 32 ASCII characters. This information will be provided by the central station system administrator.

### [207] Cellular Receiver 1 Supervision Interval

Default (0087/135 seconds)

The supervision interval is only valid if supervision has been enabled for Cellular receiver 1 in section [200]. The receiver supervision interval determines the delay, in seconds, between each heartbeat signal sent to the central station receiver. If the interval programmed is less than 10 seconds (000A), supervision is disabled. The valid range for this section is 000A – FFFF seconds.

**NOTE:** The supervision interval programmed in the central station receive must be 65s longer than the interval programmed in the communicator to ensure stable operation.

## Cellular Receiver 2 Options

### [210] Cellular Receiver 2 Options

**Option 1:** Cellular Receiver 2 Enabled - Default ON/OFF

**ON:** Cellular receiver 2 is enabled.

**OFF:** Cellular receiver 2 is disabled.

**Options 2:** Cellular Receiver 2 Supervision Enabled - Default OFF

**ON:** Cellular receiver 2 is supervised and heartbeats are sent to cellular receiver 2 based on the supervision interval programmed in section [217].

**OFF:** Cellular receiver 2 is not supervised.

#### [211] Cellular Receiver 2 Account Code

Default (0000000000)

The account code is used by the central station to distinguish between different transmitters. This account code is used when transmitting signals to the central station receiver. Signals received on the panel will use the panel account number. Valid range: 0000000001 - FFFFFFFF0E.

**NOTE:** Programming this section as all 0's or F's will cause a module configuration trouble (yellow LED = 12 flashes).

#### [212] Cellular Receiver 2 DNIS

Default (000000)

The DNIS is used in addition to the account code to identify the communicator module at the central station. Valid range: 000000 - 099999. Values are entered as a 0 followed by the 5-digit DNIS value. Format is BCD.

#### [213] Cellular Receiver 2 Address

Default (000.000.000.000)

Enter the cellular receiver 2 IP address. This IP address will be provided by the central station. Format is 4 fields, each field is 3-digit decimal. Valid range: 000 - 255.

**NOTE:** When a valid address has been entered, cellular receiver 2 is enabled and will communicate events over the cellular path.

#### [214] Cellular Receiver 2 Port

Default (0BF5/3061)

This section defines the port of cellular receiver 2. Change the value of this port when the installation is located behind a fire-wall and must be assigned a particular port number, as determined by the central station system administrator. Valid range: 0000 - FFFF.

**NOTE:** Do not program cellular receiver 1 and cellular receiver 2 to communicate to the same receiver.

#### [215] Cellular Receiver 2 APN

Default ( )

The APN determines the cellular network that the communicator will connect to. This information is available from the network carrier. Program this section with up to 32 ASCII characters.

**NOTE:** When a SIM card with a custom APN is used, the unit will not have access to the Internet. DLS and remote flash can still be done if section [221] is programmed with a valid public APN.

#### [216] Cellular Receiver 2 Domain Name

Default ( )

Enter the cellular receiver 2 Domain Name with up to 32 ASCII characters.

#### [217] Cellular Receiver 2 Supervision Interval

Default (0087/135 seconds)

The supervision interval is only valid when supervision has been enabled for Cellular receiver 2 in section [200]. The receiver supervision interval determines the delay, in seconds, between each heartbeat signal sent to the central station receiver. If the interval programmed is less than 10 seconds (000A) then supervision is disabled. The valid range for this section is 000A - FFFF seconds.

**NOTE:** The supervision interval programmed in the central station receiver must be 65s longer than the interval programmed in the communicator to ensure stable operation.

## Cellular Options

#### [221] Cellular Public Access Point Name

Default ( )

When the communicator is operating on a private APN, use this section to select a public APN for DLS and remote firmware update. This information is available from the network carrier. The APN identifies the public cellular network that the communicator will connect to.

#### [222] Cellular Login User Name

Default ( )

Some network carriers require login credentials when connecting to an APN. Program the login user name in this section. Enter the Cellular Login User Name with up to 32 ASCII characters.

### [223] Cellular Login Password

Default ( )

Some network carriers require login credentials when connecting to an APN. Program the login password in this section. Enter the Cellular Login Password with up to 32 ASCII characters.

### [224] Cellular Test Transmission Time of Day

Default (9999)

Enter a 4-digit value using the 24-hour clock format (HHMM) to set the test transmission time of day. Valid range: 00-23 for the hours (HH) and 00-59 for the minutes (MM).

**NOTE:** To disable the test transmission time of day enter 9999 or FFFF in this section.

The internal date and time will be automatically programmed by the primary receiver only.

### [225] Cellular Test Transmission Cycle

Default (000000)

This value represents the interval in between test transmissions in minutes. Valid range: 000000 - 999999 minutes. Once the unit has sent the initial periodic test transmission, all future test transmissions will be offset by the programmed number of minutes. See sections [026] - [029].

Table 18: Cellular Test Transmission Interval

Test Transmission Interval	Daily	Weekly	Monthly
Programmed Minutes	001440	010080	043200

**NOTE:** Minimum value is 000005 minutes. Programming an interval that is less than 5 minutes will disable test transmission.

### [226] Network Trouble Delay

Default (0F)

This option is used to program the delay, in minutes, for reporting a cellular trouble delay. Valid entries are 00 - FF. (e.g., for a 10 minute cellular trouble delay enter: 0A). When this section is programmed as 00, Cellular, Ethernet and Supervision troubles are not communicated.

### [227] Voice Call Timeout

Default (00) Valid entries are 00 - FF.

### [228] Voice Call Back Time

Default (0A) Valid entries are 00 - FF.

### [229] Voice Call Back Number

Default ( ) 32-digit phone number.

### [237] Primary Cellular DNS IP

Default (000.000.000.000)

Enter the IP address for the primary cellular DNS IP used by the radio. Format is 4 fields, each field is a 3-digit decimal entry ranging from 000 to 255. If the IP is 0.0.0.0 the radio will use the domain name server provided by the cellular network provider.

**NOTE:** Private cellular networks require public IP access in order to reach DNS servers outside of the private network infrastructure.

### [238] Backup Cellular DNS IP

Default (000.000.000.000)

Enter the IP address for the backup cellular DNS IP used by the radio. Format is 4 fields, each field is a 3-digit decimal entry ranging from 000 to 255. If the IP is 0.0.0.0 the radio will use the domain name server provided by the cellular network provider.

**NOTE:** Private cellular networks require a public APN in order to use DNS servers outside of the private network infrastructure.

## SMS Event Notification/Command and Control Options

When an event is triggered by the panel and SMS notification is ON in section [301] toggle option [1], an SMS message is sent to the SMS telephone numbers programmed in sections [311]-[342]. Event types that trigger notifications are specified in sections [343]-[374] if toggle [7] is ON. The system will make one attempt to send the SMS message to each of the programmed telephone numbers, starting with the first number. If it is unsuccessful, the SMS message will be sent to each of the remaining numbers, in sequence, until successful or all numbers are used.

The SMS event notification message is formatted in five parts as follows:

Account Label [351], Date and Time [DD/MM/YY HH:MM], Partition Label programmed in panel, Event Label [451]-[596], and User Label programmed in panel (or Zone Label programmed in panel).

Extra spaces in each of the five parts of the message are removed when the SMS message is composed. If the message is too long, all extra characters are removed and will not be included in the SMS message.

**NOTE:** If a panel event occurs during an SMS transmission, the unsent SMS messages are delayed until the new event is transmitted.

**NOTE:** It may take up to four minutes from communicator power-up to synchronize the SMS time stamp with panel time.

**NOTE:** SMS Event Notification Feature is not available in North America.

### **[301] Command and Control Toggle Options**

**[1] SMS Notification Default (ON)**

**[2] Serial Communication Port Enabled Default (OFF)**

**[3] SMS Command and Control Default (ON)**

**[4] Interactive Default (OFF)**

**[5] SMS Character Format Default (OFF)**

**ON:** SMS Unicode, maximum message length is 70 characters.

**OFF:** 7 bit SMS, maximum message length is 160 characters.

**[6] Long SMS Message Handling Default (OFF)**

**ON:** If maximum message length is exceeded, it is split and sent as multiple SMS messages.

**OFF:** If maximum message length is exceeded, a single, truncated SMS message is sent.

**[7] Reserved**

**[8] Reserved**

### **[308] Outgoing SMS Retry Attempts**

Default (19) Valid entries are 00 - FF.

The default value is 25 attempts. If the communicator is having difficulty delivering an SMS message, it shall send the message again up until the number of retry attempts has been met.

### **[309] Outgoing SMS Retry Counter**

Default (0005) Valid entries are 0000 - FFFF.

If the communicator is unable to deliver an SMS message, it will wait the number of seconds programmed in this section before attempting to resend the message.

### **[311]-[342] SMS Phone Number 1-32**

Default ( )

These sections may be programmed through DLS or the keypad. Up to 32 SMS telephone numbers (4-32 digits) can be programmed in sections [311]-[342]. Leaving programming blank for a telephone number will disable that number. The user can program their own mobile telephone numbers at the keypad using [\*][6] < > "SMS Programming". The SMS command and control feature uses the SMS messaging service provided by the cellular network and is subject to the limitations of SMS messaging. These limitations include delayed messages and lack of guaranteed delivery.

**NOTE:** SMS command and control (sections [601]-[618]) will only process messages from mobile telephone numbers programmed in this section if SMS command and control is enabled ([301][3] ON). SMS responses are listed in sections [621]-[630]. A blank telephone number is disabled.

### **[343]-[374] SMS Phone Number 1-32 Toggle Options**

The toggles in this section determine the type of event message that will be sent to the SMS number programmed in sections [311]-[342].

**[1] SMS Notification Alarm/Restore Default (ON)**

**[2] SMS Notification Tamper/Restore Default (ON)**

**[3] SMS Notification Opening/Closing Default (ON)**

**[4] SMS Notification System Maintenance Default (ON)**

**[5] SMS Notification System Test Default (ON)**

**[6] SMS Notification Internal Events Default (ON)**

**[7] SMS Notification Enabled Default (ON)**

**[8] SMS Command and Control Enabled Default (ON)**

### **[375]-[406] SMS Phone Number 1-32 Partition Option**

Default (00)

01-32 assigns the phone number to a partition. 01 signifies partition 1 and 32 signifies partition 32.

FF disables partition assigning for the phone number.

00 is for global partitioning. The phone number will receive notifications from all partitions.

### **[420] Serial Port Baud Rate (for use with 'R' models only)**

Default (05)

Valid entries are 01 - 05:

01 = 9600 Baud

02 = 19200 Baud

03 = 38400 Baud

04 = 57600 Baud

05 = 115200 Baud

#### **[421] Serial Port Settings (for use with 'R' models only)**

##### **[1] Parity Enabled Default (OFF)**

**ON:** Parity

**OFF:** No Parity

##### **[2] Parity Type Default (OFF)**

**ON:** Odd Parity

**OFF:** Even Parity

##### **[3] Stop Bits Default (OFF)**

**ON:** Two Stop Bits

**OFF:** One Stop Bit

##### **[4] Flow Control Default (OFF)**

**ON:** Flow Control

**OFF:** No Flow Control

##### **[5] - [8] Reserved**

#### **[422] Integration Identification Number**

This section will display the unique 12-digit number assigned to this communicator for the identification when integrated with third party applications.

#### **[423] Session 1 Integration Access Code**

Default (12345678) Valid Range is 00000000 - FFFFFFFF

This section is a programmable 8-digit number used for initialization with third party applications.

#### **[424] Session 1 SMS Label**

Default (11111111)

Program this section with a label that is used to validate a connection between the communicator and third party software over cellular.

#### **[425] Session 1 Integration Toggle Options 2**

The toggle options in this section are used to enable and configure the path used for integration with third party applications.

##### **[1] Integration Over Serial Port Default (ON)**

##### **[2] Integration Over Cellular Default (OFF)**

##### **[3] Integration Over Ethernet Default (OFF)**

Note: Only one serial or cellular integration session can be configured for use with the product. Cellular integration is only available outside of the USA/Canada.

TL280LE / TL2803G v5.5 Dual Path Ethernet/Cellular communicators allow one integration session to use the Ethernet channel as the primary connection to a remote integration server, and if Ethernet fails due to an ISP trouble, connect to the integration solution using cellular instead. To enable the Integration Backup feature on dual-path communicators, enable option [3] Integration over Ethernet and [2] Integration over Cellular in section [425], and ensure Option [4] is disabled in section [005] so Ethernet is the primary technology used for communications.

The communicator will automatically reconnect to the server using Ethernet when the path restores.

Integration Backup is supported when no polling, UDP polling, or TCP polling applications are used.

Before using this feature, confirm with the integration partner if it is allowed, and that an adequate data plan is active on the SIM card.

##### **[4] Type 2 Encryption Default (OFF)**

##### **[5] Integration Protocol Default (ON)**

##### **[6] Interactive Protocol SMA Default (OFF)**

##### **[7] Reserved**

##### **[8] Interactive Encryption for SMA Default (ON)**

#### **[426] Session 1 Integration Toggle Options 3**

The toggle options in this section are used to determine the polling and notification behavior used for integration with third party applications.

##### **[1] UDP Polling Default (OFF)**

##### **[2] TCP Polling Default (OFF)**

##### **[3] Real-time Notification Default (OFF)**

[4] **Notification Follows Poll** Default (OFF)

[5] **Reserved**

[6] **Reserved**

[7] **Reserved**

[8] **Reserved**

**[427] Session 1 Interactive Polling Interval in Seconds**

Default (000A)

This option controls the polling interval from the alarm panel to the integration interface for the purpose of optimizing data usage. The shorter the interval, the higher the data usage.

Valid range: 0000-FFFF

**[428] Session 1 Integration Server IP**

This section displays the IP address of the third party server. **Do not** program this section if a domain name is programmed in setion [431].

**[429] Session 1 Integration Notification Port**

Default (0C00/3072)

This section is used to program the TCP Integration port for real time notification.

**[430] Session 1 Integration Polling Port**

Default (0C01/3073)

This section is used to program the integration server port. Refer to third party device manual for more information.

**[431] Session 1 Integration Server DNS**

Enter the domain name (up to 32 ASCII characters) as provided by a third-party device. Refer to third party device manual for more information.

**[432] Session 1 Integration Outgoing Port**

Default (0C04/3076)

This section is used to program the outgoing port for integration via UDP.

**[433] Session 1 Integration Incoming Port**

Default (0BFF/3071)

This section is used to program incoming port for integration via TCP.

**[434] Session 1 Notification Zone 1-8 Toggle**

- [1] Zone 1 (ON)
- [2] Zone 2 (ON)
- [3] Zone 3 (ON)
- [4] Zone 4 (ON)
- [5] Zone 5 (ON)
- [6] Zone 6 (ON)
- [7] Zone 7 (ON)
- [8] Zone 8 (ON)

**[435] Session 1 Notification Zone 9-16 Toggle**

- [1] Zone 9 (ON)
- [2] Zone 10 (ON)
- [3] Zone 11 (ON)
- [4] Zone 12 (ON)
- [5] Zone 13 (ON)
- [6] Zone 14 (ON)
- [7] Zone 15 (ON)
- [8] Zone 16 (ON)

**[436] Session 1 Notification Zone 17-24**

- [1] Zone 17 (ON)
- [2] Zone 18 (ON)
- [3] Zone 19 (ON)
- [4] Zone 20 (ON)
- [5] Zone 21 (ON)
- [6] Zone 22 (ON)
- [7] Zone 23 (ON)
- [8] Zone 24 (ON)

**[437] Session 1 Notification Zone 25-32 Toggle**

- [1] Zone 25 (ON)
- [2] Zone 26 (ON)
- [3] Zone 27 (ON)
- [4] Zone 28 (ON)
- [5] Zone 29 (ON)
- [6] Zone 30 (ON)
- [7] Zone 31 (ON)
- [8] Zone 32 (ON)

**[438] Session 1 Notification Zone 33-40**

- [1] Zone 33 (ON)

**[439] Session 1 Notification Zone 41-48 Toggle**

- [1] Zone 41 (ON)

- [2] Zone 34 (ON)
- [3] Zone 35 (ON)
- [4] Zone 36 (ON)
- [5] Zone 37 (ON)
- [6] Zone 38 (ON)
- [7] Zone 39 (ON)
- [8] Zone 40 (ON)

**[440] Session 1 Notification Zone 49-56**

- [1] Zone 49 (ON)
- [2] Zone 50 (ON)
- [3] Zone 51 (ON)
- [4] Zone 52 (ON)
- [5] Zone 53 (ON)
- [6] Zone 54 (ON)
- [7] Zone 55 (ON)
- [8] Zone 56 (ON)

**[442] Session 1 Notification Zone 65-72**

- [1] Zone 65 (ON)
- [2] Zone 66 (ON)
- [3] Zone 67 (ON)
- [4] Zone 68 (ON)
- [5] Zone 69 (ON)
- [6] Zone 70 (ON)
- [7] Zone 71 (ON)
- [8] Zone 72 (ON)

**[444] Session 1 Notification Zone 81-88**

- [1] Zone 81 (ON)
- [2] Zone 82 (ON)
- [3] Zone 83 (ON)
- [4] Zone 84 (ON)
- [5] Zone 85 (ON)
- [6] Zone 86 (ON)
- [7] Zone 87 (ON)
- [8] Zone 88 (ON)

**[446] Session 1 Notification Zone 97-104**

- [1] Zone 97 (ON)
- [2] Zone 98 (ON)
- [3] Zone 99 (ON)
- [4] Zone 100 (ON)
- [5] Zone 101 (ON)
- [6] Zone 102 (ON)
- [7] Zone 103 (ON)

- [2] Zone 42 (ON)
- [3] Zone 43 (ON)
- [4] Zone 44 (ON)
- [5] Zone 45 (ON)
- [6] Zone 46 (ON)
- [7] Zone 47 (ON)
- [8] Zone 48 (ON)

**[441] Session 1 Notification Zone 57-64 Toggle**

- [1] Zone 57 (ON)
- [2] Zone 58 (ON)
- [3] Zone 59 (ON)
- [4] Zone 60 (ON)
- [5] Zone 61 (ON)
- [6] Zone 62 (ON)
- [7] Zone 63 (ON)
- [8] Zone 64 (ON)

**[443] Session 1 Notification Zone 73-80 Toggle**

- [1] Zone 73 (ON)
- [2] Zone 74 (ON)
- [3] Zone 75 (ON)
- [4] Zone 76 (ON)
- [5] Zone 77 (ON)
- [6] Zone 78 (ON)
- [7] Zone 79 (ON)
- [8] Zone 80 (ON)

**[445] Session 1 Notification Zone 89-96 Toggle**

- [1] Zone 89 (ON)
- [2] Zone 90 (ON)
- [3] Zone 91 (ON)
- [4] Zone 92 (ON)
- [5] Zone 93 (ON)
- [6] Zone 94 (ON)
- [7] Zone 95 (ON)
- [8] Zone 96 (ON)

**[447] Session 1 Notification Zone 105-112 Toggle**

- [1] Zone 105 (ON)
- [2] Zone 106 (ON)
- [3] Zone 107 (ON)
- [4] Zone 108 (ON)
- [5] Zone 109 (ON)
- [6] Zone 110 (ON)
- [7] Zone 111 (ON)

[8] Zone 104 (ON)

[8] Zone 112 (ON)

**[448] Session 1 Notification Zone 113-120**

**[449] Session 1 Notification Zone 121-128 Toggle**

[1] Zone 113 (ON)

[1] Zone 121 (ON)

[2] Zone 114 (ON)

[2] Zone 122 (ON)

[3] Zone 115 (ON)

[3] Zone 123 (ON)

[4] Zone 116 (ON)

[4] Zone 124 (ON)

[5] Zone 117 (ON)

[5] Zone 125 (ON)

[6] Zone 118 (ON)

[6] Zone 126 (ON)

[7] Zone 119 (ON)

[7] Zone 127 (ON)

[8] Zone 120 (ON)

[8] Zone 128 (ON)

**[450]-[476] Repeats [423]-[449] for Session 2**

**[691]-[692] Session 1 to 2 Notification Control**

[1]: Alarm and Alarm Restore Notifications

[2]: Tamper and Tamper Restore Notifications

[3]: Arming and Disarming Notifications

[4]: System Maintenance Notifications

[5]: Test Transmission Notifications

[6]-[8]: For Future Use

**[700] to [701] Session 1 – 2 (Type 2) Integration Access Code**

Default (12345678123456781234567812345678); Valid range: (00000000000000000000000000000000 to FFFFFFFFFFFFFFFF FFFFFFFFFFFFFFFF).

**NOTE:** Do not program all 0s or Fs in this section.

These sections display the programmable 32-digit number used for initialization of 3rd party integrations that use Type 2 Encryption.

**[708] Event Report Retry Interval**

Default (0A14285000000000) Valid range: 0000000000000000 - FFFFFFFFFFFFFFFF.

**[709] Event Report Retry Timeout**

Default (0000012C) Valid range: 00000000 - FFFFFFFF.

**[710] Lifestyle Event Log Sync Timeout**

Default (00015180) Valid range: 00000000 - FFFFFFFF.

**[711] Integration Inactivity Timeout**

Default (0000012C) Valid range: 00000000 - FFFFFFFF.

**[716] Lifestyle Reset Window**

Default (0E10) Valid range: 0000 - FFFF.

**[720] Local Debug TCP Port**

Default (0000) Valid range: 0000 - FFFF.

**[722] Lifestyle Zone 1-8 Toggle**

**[723] Lifestyle Zone 9-16 Toggle**

[1] Zone 1 (ON)

[1] Zone 9 (ON)

[2] Zone 2 (ON)

[2] Zone 10 (ON)

[3] Zone 3 (ON)

[3] Zone 11 (ON)

[4] Zone 4 (ON)

[4] Zone 12 (ON)

[5] Zone 5 (ON)

[5] Zone 13 (ON)

[6] Zone 6 (ON)

[6] Zone 14 (ON)

[7] Zone 7 (ON)

[7] Zone 15 (ON)

[8] Zone 8 (ON)

[8] Zone 16 (ON)

**[724] Lifestyle Zone 17-24 Toggle**

- [1] Zone 17 (ON)
- [2] Zone 18 (ON)
- [3] Zone 19 (ON)
- [4] Zone 20 (ON)
- [5] Zone 21 (ON)
- [6] Zone 22 (ON)
- [7] Zone 23 (ON)
- [8] Zone 24 (ON)

**[725] Lifestyle Zone 25-32 Toggle**

- [1] Zone 25 (ON)
- [2] Zone 26 (ON)
- [3] Zone 27 (ON)
- [4] Zone 28 (ON)
- [5] Zone 29 (ON)
- [6] Zone 30 (ON)
- [7] Zone 31 (ON)
- [8] Zone 32 (ON)

**[726] Lifestyle Zone 33-40 Toggle**

- [1] Zone 33 (ON)
- [2] Zone 34 (ON)
- [3] Zone 35 (ON)
- [4] Zone 36 (ON)
- [5] Zone 37 (ON)
- [6] Zone 38 (ON)
- [7] Zone 39 (ON)
- [8] Zone 40 (ON)

**[727] Lifestyle Zone 41-48 Toggle**

- [1] Zone 41 (ON)
- [2] Zone 42 (ON)
- [3] Zone 43 (ON)
- [4] Zone 44 (ON)
- [5] Zone 45 (ON)
- [6] Zone 46 (ON)
- [7] Zone 47 (ON)
- [8] Zone 48 (ON)

**[728] Lifestyle Zone 49-56 Toggle**

- [1] Zone 49 (ON)
- [2] Zone 50 (ON)
- [3] Zone 51 (ON)
- [4] Zone 52 (ON)
- [5] Zone 53 (ON)
- [6] Zone 54 (ON)
- [7] Zone 55 (ON)
- [8] Zone 56 (ON)

**[729] Lifestyle Zone 57-64 Toggle**

- [1] Zone 57 (ON)
- [2] Zone 58 (ON)
- [3] Zone 59 (ON)
- [4] Zone 60 (ON)
- [5] Zone 61 (ON)
- [6] Zone 62 (ON)
- [7] Zone 63 (ON)
- [8] Zone 64 (ON)

**[730] Lifestyle Zone 65-72 Toggle**

- [1] Zone 65 (ON)
- [2] Zone 66 (ON)
- [3] Zone 67 (ON)
- [4] Zone 68 (ON)
- [5] Zone 69 (ON)
- [6] Zone 70 (ON)
- [7] Zone 71 (ON)
- [8] Zone 72 (ON)

**[731] Lifestyle Zone 73-80 Toggle**

- [1] Zone 73 (ON)
- [2] Zone 74 (ON)
- [3] Zone 75 (ON)
- [4] Zone 76 (ON)
- [5] Zone 77 (ON)
- [6] Zone 78 (ON)
- [7] Zone 79 (ON)
- [8] Zone 80 (ON)

**[732] Lifestyle Zone 81-88 Toggle**

- [1] Zone 81 (ON)
- [2] Zone 82 (ON)
- [3] Zone 83 (ON)

**[733] Lifestyle Zone 89-96 Toggle**

- [1] Zone 89 (ON)
- [2] Zone 90 (ON)
- [3] Zone 91 (ON)

- [4] Zone 84 (ON)
- [5] Zone 85 (ON)
- [6] Zone 86 (ON)
- [7] Zone 87 (ON)
- [8] Zone 88 (ON)

- [4] Zone 92 (ON)
- [5] Zone 93 (ON)
- [6] Zone 94 (ON)
- [7] Zone 95 (ON)
- [8] Zone 96 (ON)

**[734] Lifestyle Zone 97-104 Toggle**

- [1] Zone 97 (ON)
- [2] Zone 98 (ON)
- [3] Zone 99 (ON)
- [4] Zone 100 (ON)
- [5] Zone 101 (ON)
- [6] Zone 102 (ON)
- [7] Zone 103 (ON)
- [8] Zone 104 (ON)

**[735] Lifestyle Zone 105-112 Toggle**

- [1] Zone 105 (ON)
- [2] Zone 106 (ON)
- [3] Zone 107 (ON)
- [4] Zone 108 (ON)
- [5] Zone 109 (ON)
- [6] Zone 110 (ON)
- [7] Zone 111 (ON)
- [8] Zone 112 (ON)

**[736] Lifestyle Zone 113-120 Toggle**

- [1] Zone 113 (ON)
- [2] Zone 114 (ON)
- [3] Zone 115 (ON)
- [4] Zone 116 (ON)
- [5] Zone 117 (ON)
- [6] Zone 118 (ON)
- [7] Zone 119 (ON)
- [8] Zone 120 (ON)

**[737] Lifestyle Zone 121-128 Toggle**

- [1] Zone 121 (ON)
- [2] Zone 122 (ON)
- [3] Zone 123 (ON)
- [4] Zone 124 (ON)
- [5] Zone 125 (ON)
- [6] Zone 126 (ON)
- [7] Zone 127 (ON)
- [8] Zone 128 (ON)

## External Event Label Programming

### [738]-[883] Event Labels

Default (see Label Number in table);

There are 143 programmable event labels. Each label is pre-programmed with the default text shown in the table. Each label is up to 32 ASCII characters (including spaces). The language is specified in section [009].

Table 19: External Event Labels

Event [Section] Label	Default Label	Event [Section] Label	Default Label
[738] Burglary Alarm	(Burglary Alarm)	[739] Burglary Alarm Restore	(Burglary Alarm Restore)
[740] Fire Alarm	(Fire Alarm)	[741] Fire Alarm Restore	(Fire Alarm Restore)
[742] 24 Hour Alarm	(24 Hour Alarm)	[743] 24 Hour Alarm Restore	(24 Hour Alarm Restore)
[744] Holdup Alarm	(Holdup Alarm)	[745] Holdup Alarm Restore	(Holdup Alarm Restore)
[746] Gas Alarm	(Gas Alarm)	[747] Gas Alarm Restore	(Gas Alarm Restore)
[748] High Temperature Alarm	(High Temperature Alarm)	[749] High Temperature Alarm Restore	(High Temperature Alarm Restore)
[750] Medical Alarm	(Medical Alarm)	[751] Medical Alarm Restore	(Medical Alarm Restore)
[752] Panic Alarm	(Panic Alarm)	[753] Panic Alarm Restore	(Panic Alarm Restore)
[754] Emergency Alarm	(Emergency Alarm)	[755] Emergency Alarm Restore	(Emergency Alarm Restore)
[756] Sprinkler Alarm	(Sprinkler Alarm)	[757] Sprinkler Alarm Restore	(Sprinkler Alarm Restore)
[758] Water Level Alarm	(Water Level Alarm)	[759] Water Level Alarm Restore	(Water Level Alarm Restore)
[760] Low Temperature Alarm	(Low Temperature Alarm)	[761] Low Temperature Alarm Restore	(Low Temperature Alarm Restore)
[762] Fire Supervisory	(Fire Supervisory)	[763] Fire Supervisory Restore	(Fire Supervisory Restore)
[764] CO Alarm	(CO Alarm)	[765] CO Alarm Restore	(CO Alarm Restore)
[766] Water Alarm	(Flood Alarm)	[767] Water Alarm Restore	(Flood Alarm Restore)
[768] Quick Bypass Alarm	(Quick Bypass Alarm )	[769] Quick Bypass Alarm Restore	(Quick Bypass Alarm Restore)
[770] Aux Alarm	(Aux Alarm)	[771] Aux Alarm Restore	(Aux Alarm Restore)
[772] Zone Expander Supervisory Alarm	(Zone Expander Supervisory Alarm)	[773] Zone Expander Sup Alarm Restore	(Zone Expander Sup Alarm Restore)
[774] Duress Alarm	(Duress Alarm)	[775] Account Label	(Security System)
[776] General System Tamper	(General System Tamper)	[777] General System Tamper Restore	(General System Tamper Restore)
[778] General System Trouble	(General System Trouble)	[779] General System Restore	(General System Restore)
[780] Panel AC Power Trouble Label	(AC Power Trouble)	[781] Panel AC Power Restore Label	(AC Power Restore)
[782] Panel Auxiliary Power Trouble	(Panel Auxiliary Power Trouble)	[783] Panel Auxiliary Power Restore	(Panel Auxiliary Power Restore)

<b>Event [Section] Label</b>	<b>Default Label</b>	<b>Event [Section] Label</b>	<b>Default Label</b>
[784] Panel Battery Trouble	(Battery Trouble)	[785] Panel Battery Restore	(Battery Trouble Restore)
[786] Panel Bell Circuit Trouble	(Panel Bell Circuit Trouble)	[787] Panel Bell Circuit Restore	(Panel Bell Circuit Restore)
[788] Panel Telephone Line Trouble	(Panel Telephone Line Failure)	[789] Panel Telephone Line Restore	(Panel Telephone Line Restore)
[790] Fail to Communicate Trouble	(Fail to Communicate Trouble)	[791] Fail to Communicate Restore	(Fail to Communicate Restore)
[792] Fire Trouble	(Fire Trouble)	[793] Fire Trouble Restore	(Fire Trouble Restore)
[794] Zone Tamper	(Zone Tamper)	[795] Zone Tamper Restore	(Zone Tamper Restore)
[796] Zone Fault	(Zone Fault)	[797] Zone Fault Restore	(Zone Fault Restore)
[798] Alternate Communicator Trouble	(Alternate Communicator Trouble)	[799] Alternate Communicator Restore	(Alternate Communicator Restore)
[800] Module Trouble	(Module Trouble)	[801] Module Trouble Restore	(Module Trouble Restore)
[802] Wireless/AML Device Trouble	(Device Trouble)	[803] Wireless/AML Device Restore	(Device Trouble Restore)
[804] Disarmed By	(Disarmed By)	[805] Armed By	(Armed By)
[806] Disarmed	(Disarmed)	[807] Armed	(Armed)
[808] Automatic Disarming	(Automatic Disarming)	[809] Automatic Arming	(Automatic Arming )
[810] Automatic Arming Cancelled	(Automatic Arming Cancelled)	[811] Late to Open	(Late to Open)
[812] Late to Close	(Late to Close)	[813] Disarmed After Alarm	(Disarmed After Alarm)
[814] Alarm Occurred After Arming	(Alarm Occurred After Arming)	[815] Exit Fault	(Exit Fault)
[816] Cold Start	(Cold Start)	[817] Armed With Zones Bypassed	(Armed With Zones Bypassed)
[818] Zone Bypassed	(Zone Bypassed)	[819] Zone Unbypassed	(Zone Unbypassed)
[820] Burglary Verified	(Burglary Verified)	[821] Burglary Not Verified	(Burglary Not Verified)
[822] Alarm Cancelled	(Alarm Cancelled)	[823] Holdup Verified	(Holdup Verified)
[824] Walk Test Begin	(Walk Test Begin)	[825] Walk Test End	(Walk Test End)
[826] System Test	(Test Message)	[827] Periodic Test Transmission	(Periodic Test)
[828] Periodic Test With Trouble	(Periodic Test With Trouble)	[829] DLS Remote Programming Begin	(Remote Programming Begin)
[830] DLS Remote Programming End	(Remote Programming End)	[831] SA Remote Programming Begin	(Remote Programming Begin)
[832] SA Remote Programming End	(Remote Programming End)	[833] Installer Lead In	(Local Programming Begin)
[834] Installer Lead Out	(Local Programming End)	[835] Firmware Update Begin	(Firmware Update Begin)
[836] Firmware Update Successful	(Firmware Update Successful)	[837] Firmware Update Fail	(Firmware Update Fail)

Event [Section] Label	Default Label	Event [Section] Label	Default Label
[838] Delinquency	(Delinquency)	[839] Keypad Lockout	(Keypad Lockout)
[840] Event Log 75% full	(Buffer Near Full)	[841] FTC Trouble	(Fail to communicate trouble)
[842] FTC Restore	(fail to communicate restore)	[843] Panel Absent Trouble	(Panel Communications Trouble)
[844] Panel Absent Trouble Restore	(Panel Communications Restore)	[845] Module Reprogramming	(Communicator Programming Updated)
[846] Firmware Update	(Communicator Firmware Updated)	[850] Module	(Module)
[851] Stay Arm	(Stay Arm)	[852] Away Arm	(Away Arm)
[853] Night Arm	(Night Arm)	[854] Disarm	(Disarm)
[855] Activate Command Output 1	(Activate Command Output 1)	[856] Activate Command Output 2	(Activate Command Output 2)
[857] Activate Command Output 3	(Activate Command Output 3)	[858] Activate Command Output 4	(Activate Command Output 4)
[859] Deactivate Command Output 1	(Deactivate Command Output 1)	[860] Deactivate Command Output 2	(Deactivate Command Output 2)
[861] Deactivate Command Output 3	(Deactivate Command Output 3)	[862] Deactivate Command Output 4	(Deactivate Command Output 4)
[863] Bypass	(Bypass)	[864] Unbypass	(Unbypass)
[865] Status Request	(Status Request)	[866] Alarm Memory Request	(Alarm Memory Request)
[867] Help	(Help)	[868] Pay As You Go Balance Request	(Balance Request)
[869] Keypad Message	(Keypad Message)	[870] Function Successful	(Successful)
[871] Function Failure	(Unsuccessful)	[872] Invalid Command	(Invalid Command)
[873] System Stay Armed	(Stay Armed)	[874] System Away Armed	(Away Armed)
[875] System Night Armed	(Night Armed)	[876] System Disarmed Ready	(Disarmed Ready)
[877] System Disarmed, Not Ready	(Disarmed Not Ready)	[878] System In Alarm	(is in Alarm)
[879] Trouble Label	(Service is Required)	[880] No Alarms in Memory	(No Alarms in Memory)
[881] Pay As You Go Balance	(Pay as you go balance.)	[882] Pay As You Go Message	(*123#)
[883] Response Code	(Response Code)		

## Receiver Diagnostic Testing

### [901] Diagnostic Test Transmission

[1] Ethernet 1 Default (OFF).

[2] Ethernet 2 Default (OFF).

[3] Cellular 1 Default (OFF).

[4] Cellular 2 Default (OFF).

[5],[6],[7],[8] Reserved (OFF).

This section may be used by the installer to force the communicator to send an immediate test transmission to specific receivers, to verify that the communications paths are available. Diagnostic test transmission failure will indicate as FTC trouble (yellow LED = 9 flashes). If an FTC error occurs when testing all receivers, select only one receiver and repeat test to isolate the receiver that is not communicating.

**NOTE:** Sending a test transmission to a receiver that is not programmed generates an FTC trouble.

## **[902] Load Programming Template**

### **[01] – Connect Alarm – Ethernet**

### **[02] – Connect Alarm - Cellular**

Enter 01 in section [902] to automatically configure Integration Session 1 for use with the Connect Alarm mobile app using the Ethernet Channel. Available in TL280, TL2803G and TL280LE models only.

Enter 02 in section [902] to automatically configure Integration Session 1 for use with the Connect Alarm mobile app using the Cellular Channel. Available in TL280LE/TL2803G/LE2080/3G2080 models only.

The template will also automatically program the account codes saved in sections [101] or [201] with a unique value derived from the integration ID in section [422].

Refer to the Connect Alarm Programming guide found on [www.dsc.com](http://www.dsc.com) for a complete description of the settings applied through the template.

### **[961] Cellular Inactivity Timeout**

Default (41) Valid entries are 00 - FF.

## **System Information (Read Only)**

**NOTE:** Sections [971] - [998] are provided for information (read-only). Values in these sections cannot be modified by the installer.

### **[971] - EEPROM Map Version**

### **[972] - Virtual Keypad Language Version**

### **[976] - Radio Configuration File Version**

### **[977] - Cellular Network Provider - MCC/MNC Code**

### **[978] - Cellular Network Type**

00	GPRS	2G	04	LTE	4G
01	EDGE	2G	05	LTE Advanced	4G
02	WCDMA	3G	06	CDMA	2G
03	HSDPA	3G	07	EVDO	3G

### **[979] - Cellular Network CSQ**

### **[980] - Radio Reset Codes**

### **[981] - Radio Type**

### **[982] - Radio Firmware Version**

### **[983] - Firmware Update Diagnostics Section**

Table 20: Response Code Descriptions and Corresponding Actions

Response Code	Description of Response Code	Corresponding Action
<b>Bad File</b>		
00	Version check failed	Contact DSC Tech Support, describe the action attempted with the system and supply them with the Response Code in Section [983].
01	Image type mismatch	
02	Device type mismatch	
03	Hardware type mismatch	
04	General variant mismatch	
05	Firmware header wrong length	
<b>Panel is Busy</b>		
20	System update pending - panel is armed	Disarm the panel to continue with system firmware update process.
21	System update pending -AC trouble (Any AC trouble; device/module)	Resolve the AC trouble to continue with system firmware update process.
22	System update pending -low battery (Any low battery trouble; device/module)	Resolve the low battery trouble to continue with system firmware update process.
25	System update pending - communication in progress	Retry in a few minutes; if issue persists, contact DSC Tech Support.
<b>Firmware Update Sequence Change</b>		
A0	System firmware update successful	None
A1	System firmware update failure	At least one module was not updated. Use DLS to reapply the firmware to the module not updated.
A2	System firmware update failure - module not found	At least one module was not responding during firmware update. Ensure all modules enrolled are physically connected and powered up.
AA	Device firmware transfer begin	None
AB	Device firmware module update begin	None
AC	General device firmware transfer failure	Contact DSC Tech Support, describe the action attempted with the system and supply them with the Response Code in Section [983].
<b>Firmware Update Status</b>		
C0	System ready to update.	None
C1	System update cancel request received	The system has received an update cancel request from DLS.
C2	System update begin	None
<b>Firmware Download Request Reject</b>		

Response Code	Description of Response Code	Corresponding Action
E0	Reserved	
E1		
E2		
E3		
E4		
E5	Remote firmware update disabled	Enable remote firmware update in the communicator in order to perform remote system firmware update.
<b>Local Status Update States</b>		
FE	Firmware file empty	No action required. Communicator currently does not have any firmware files.
FD	Firmware download in progress	No action required. Communicator is currently downloading firmware.

The table above displays firmware update indicator codes and meaning of each code. The updates can be made from communicator. The communicator can update firmware of the panel and also of the communicator itself. This section does not provide specific details such as if the image is still stored or erased due to the cancellation code.

#### [984] Communicator Status

The communicator status sections provide the installer with the status of the communicator's functionality, operational readiness, and failures.

The communicator status is displayed as a 6-digit hexadecimal code. The code ranges between 00000F and 2220CF, though not all numbers in this range are assigned. Each of the 6 digits represents a status or trouble indicator as below:

1. Digits 1 and 2: Signal strength indicators display the presence/strength of cellular radio.
2. Digit 3: Network Indicator, indicates the operational status of the network.
3. Digits 4 and 5: Trouble Indicator displays the type of issue on the communicator or modules associated with and connected to the communicator. See Table 8 on page 17 for a listing of possible values.
4. Digit 6: Reserved, displays as 'F' or '-'.  
For example, a value of 11002F means:

11- Signal strength is excellent

0 - No network issues

02 - Panel supervision trouble with the communicator

The status code for the radio signal strength, its typical troubles, possible causes and troubleshooting instructions is displayed in the following table.

Table 21: Radio Signal Strength - Digits 1 and 2

Signal Strength	CSQ Level	Signal Indicator 1	Signal Indicator 2	Signal Level [dBm]	Signal Level Status	Action Required
No Signal	0	0	0	-108.8	bad	Check all antenna connections. Confirm cellular service is active in area. Relocate panel or install external antenna.
1 Bar	1 - 4	0	2	-108 ~ -103	weak	Relocate panel or install external antenna if yellow trouble LED has 5 flashes.
2 Bars	5 - 6	0	1	-102 ~ -99	weak	
3 Bars	7 - 10	2	1	-98 ~ -91	strong	<b>Location is OK.</b> Cellular signal strength is greater than CSQ 7.
4 Bars	11 - 13	2	1	-90 ~ -85	strong	
5 Bars	14 +	1	1	-84 and higher	excellent	

Table 22: Network Indicator - Digit 3

Network Indicator Value	Means
OFF	No network trouble
ON	Ethernet cable disconnected Ethernet DHCP failed
Flashing	Incoming transmission Outgoing transmission Incoming transmission

**[985] Radio Initialization Status**

The radio initialization status provides installers with the status of radio communication. It is displayed as an 8-digit toggle option, with each digit indicating a task in the initialization process.

1. Radio power up
2. Received the SMS from C24 Communications (North America only)
3. Radio reset
4. Radio attached to network
5. Receiver 1 initialized
6. Receiver 2 initialized
7. Receiver 3 initialized
8. Receiver 4 initialized

For example, the radio initialization status code 12-45--- indicates that radio has been powered up, it has received SMS signal from C24 Communications, the radio is attached to the network, and receiver 1 has been initialized. This code would update to 12-45678 when receivers 2, 3, and 4 are initialized.

If the radio initialization status code does not indicate any problems, proceed with installation as per this manual. If troubles are reported, reset the initialization process. If this does not fix the problem, refer to the troubleshooting section in this manual. The following table shows each digit position in the status code, each digit's value and its assigned meaning in the eight-digit code:

Table 23: Radio Initialization Status - 1-8 bits completion

Bit	1	2	3	4	5	6	7	8
Not Completed	-	-	-	-	-	-	-	-
Completed	1	2	3	4	5	6	7	8

**[987] Language Version**

This section will display the current language version of the communicator.

**[988] DNS 1 IP Address**

This section will display the IP address of DNS Server 1. This is useful when the unit is configured for DHCP and the IP address assigned to the device by the DHCP Server is needed. This value is programmed in Section [007] or assigned by DHCP.

**[989] DNS 2 IP Address**

This section will display the IP address of DNS Server 2. This is useful when the unit is configured for DHCP and the IP address assigned to the device by the DHCP Server is needed. This value is programmed in section [008] or assigned by DHCP.

**[990] Boot Loader Version**

This section will display the current boot loader version of the communicator.

**[991] Communicator Firmware Version**

This section will display the current firmware version of the device. Update worksheets with new version after a flash update is completed.

**[992] Ethernet IP Address**

This section will display the IP address of the Ethernet connection. This value is programmed in section [001] or assigned by DHCP.

### [993] Ethernet Gateway Address

This section will display the IP address of the Ethernet gateway. This value is programmed in section [003] or assigned by DHCP.

### [994] Cellular IP Address

This section will display the current dynamic IP address assigned by DHCP to the cellular connection.

**NOTE:** Cellular uses DHCP (dynamic IP) only. The cellular IP address is always provided by the cellular network (i.e., not programmable).

### [995] SIM Number

This section will display the Subscriber Identity Module (SIM) number of the SIM card installed in the communicator. Format is: Major Industry Identifier (2 digits); Mobile Country Code (2 or 3 digits); Mobile Network Code (2 - 3 digits); Unique Number (10 - 12 digits); and Checksum (1 digit). Valid SIM numbers range is: 18 - 21 numbers. This number is printed on the SIM and the outside of the communicator carton.

**NOTE:** The checksum digit is omitted on 19-digit SIM card numbers.

### [996] Cellular Telephone Number

**NOTE:** This section will display the cellular telephone number of the SIM. This telephone number is required by the Installer for DLS and remote firmware (flash) update. User can access this telephone number by entering [\*] [6] < > "Cellular Phone No." to display the phone number.

### [997] IMEI Number

This section will display the unique 15-digit International Mobile Equipment Identity (IMEI) of the radio. Format is: Reporting Body Identifier (2 digits), Allocation Number (4 digits); Final Assembly Code (2 digits); Serial Number (6 digits); and a check digit.

### [998] MAC Address

This section will display the unique 12-digit, hexadecimal number assigned as the Media Access Control (MAC) address of the device.

## System Reset Defaults

### [999] Software Default

Default (99);

The software default allows the installer to refresh the unit after changes and also returns the communicator to the default state.

**00: Default Module.** All programming sections in the module revert to factory settings. This will erase all existing programming of the unit.

**55: Reset.** The communicator is reset. This option is equivalent to power cycling the communicator.



# Communicator Programming Worksheets

## System Options

### [001] Ethernet IP Address

Default (000.000.000.000)

### [002] Ethernet IP Subnet Mask

Default (255.255.255.000)

### [003] Ethernet Gateway IP Address

Default (000.000.000.000)

### [005] System Toggle Options

- [3] Supervision Type (OFF).  
 [4] Primary Communications Path.  
 [OFF] TL2803G(R)E; TL280LE(R)  
 [ON] 3G2080(R)E; LE2080(R).  
 Future Use  
 [6] Remote Firmware Upgrade (ON).  
 [7] Alternate Test Transmission (OFF).  
 [8] Cellular Low Signal Trouble (OFF).

### [006] System Toggle Options 2

- [7] DLS Over Cellular (ON).  
 [8] Network Trouble Suppression (OFF).

### [007] Primary Ethernet DNS IP

Default (000.000.000.000)

### [008] Backup Ethernet DNS IP

Default (000.000.000.000)

## [009] Language

Default (01); Program label language 01-29

OPT	Language	OPT	Language	OPT	Language
01	English	11	Swedish	21	Russian
02	Spanish	12	Norwegian	22	Bulgarian
03	Portuguese	13	Danish	23	Latvian
04	French	14	Hebrew	24	Lithuanian
05	Italian	15	Greek	25	Ukrainian
06	Dutch	16	Turkish	26	Slovakian
07	Polish	17	Chinese	27	Serbian
08	Czech	18	Croatian	28	Estonian
09	Finnish	19	Hungarian	29	Slovenian
10	German	20	Romanian	30-99	Reserved

## Programming Options

### [010] System Toggle Options 3

- [1] 2-Way Audio Over Cellular (OFF)  
 [2] Visual Verification Default (OFF).  
 [3] Video On Demand (OFF)  
 [4] Receiver Group (OFF)  
 [5] Radio not in use (OFF)

### [011] Installer Code

Default (CAFE) Valid range: 0000 - FFFF.

### [012] DLS Incoming Port

Default (0BF6/3062) Valid range: 0000 - FFFF.

### [013] DLS Outgoing Port

Default (0BFA/3066) Valid range: 0000 - FFFF.

### [015] DLS Call-Up IP

Default (000.000.000.000)

### [016] DLS Call-Up Port

Default (0000) Valid range: 0000 - FFFF.

### [018] Receiver Group Programming

Default (0000) Valid range: 0000 - FFFF.

### [019] Network Profile Selection\*

Default 00. Valid range 01 - 05

- [1] Telstra  
 [2] Vodafone  
 [3] KDDI  
 [4] Softbank  
 [5] NTT Docomo (default)  
 [6] Spark

\*Australia/New Zealand only

**[020] Time Zone**

Default (00) Valid range: 00 - 99.

**[021] Account Code**

Default (FFFFFF) Valid range: 000001 - FFFFFE.

**[022] Communications Format**

Default (04) Program 03 (CID), 04 (SIA).

**[023] Panel Absent Trouble**

Default (FF); Program 00 disable or FF enable.

**[024] Panel Absent Trouble Restore**

Default (FF) Program 00 disable or FF enable.

**[025] Radio Activation Restore**

Default (FF) Program 00 disable or FF enable.

**System Test Options**

**[026] Ethernet 1 Test Transmission**

Default (FF) Program 00 disable or FF enable.

**[027] Ethernet 2 Test Transmission**

Default (00) Program 00 disable or FF enable.

**[028] Cellular 1 Test Transmission**

Default (FF) Program 00 disable or FF enable.

**[029] Cellular 2 Test Transmission**

Default (00) Program 00 disable or FF enable.

**[030] FTC Restore**

Default (FF) Program 00 disable or FF enable.

**[033] Communicator Firmware Update Begin**

Default (FF) Program 00 disable or FF enable.

**[034] Communicator Firmware Update Success**

Default (FF) Program 00 disable or FF enable.

**[095] SA Incoming Local Port**

Default (0C14/3092) Valid range: 0000 - FFFF.

**[096] SA Outgoing Local Port**

Default (0C15/3093) Valid range: 0000 - FFFF.

**[097] SA User Call Up IP**

Default (000.000.000.000)

**[098] SA User Call Up Port**

Default (0000) Valid range: 0000 - FFFF.

**[099] SA Password**

Default (FFFFFFFF) Valid range: 00000000 - FFFFFFFF.

**Ethernet Receiver 1 Options**

**[100] Ethernet Receiver 1 Options**

[1] – Ethernet Receiver 1 Enable (Default On)

[2] – Ethernet Receiver 1 Supervision Enable (Default Off)

**[101] Ethernet Receiver 1 Account Code**

Default (0000000000)

Valid range: 0000000001 - FFFFFFFF0E.

**[102] Ethernet Receiver 1 DNIS**

Default (000000) Valid range: 000000 - FFFFFF.

**[103] Ethernet Receiver 1 Address**

Default (127.000.000.001)

**[104] Ethernet Receiver 1 UDP Remote Port**

Default (0BF5/3061) Valid range: 0000 - FFFF.

**[105] Ethernet Receiver 1 UDP Local Port**

Default (0BF4/3060) Valid range: 0000 - FFFF.

**[106] Ethernet Receiver 1 Domain Name**

Default ( ) 32 ASCII characters.

**[107] Ethernet Receiver 1 Supervision Interval**

Default (0087/135 seconds) Valid Range 000A-FFFF

**Ethernet Receiver 2 Options**

**[110] Ethernet Receiver 2 Options**

[1] – Ethernet Receiver 2 Enable (Default On)

[2] – Ethernet Receiver 2 Supervision Enable (Default Off)

**[111] Ethernet Receiver 2 Account Code**

Default (0000000000)

Valid range: 0000000001 - FFFFFFFF0E.

**[112] Ethernet Receiver 2 DNIS**

Default (000000) Valid range: 000000 - 0FFFFFFF.

**[113] Ethernet Receiver 2 Address**

Default (000.000.000.000)

**[114] Ethernet Receiver 2 UDP Remote Port**

Default (0BF5/3061) Valid range: 0000 - FFFF.

**[115] Ethernet Receiver 2 UDP Local Port**

Default (0BF9/3065) Valid range: 0000 - FFFF.

**[116] Ethernet Receiver 2 Domain Name**

Default ( ) 32 ASCII characters.

**[117] Ethernet Receiver 2 Supervision Interval**

Default (0087/135 seconds)

Valid Range: 000A-FFFF

**Ethernet Options****[124] Ethernet Test Transmission Time**

Default (9999) Valid: 00-23(HH); 00-59(MM)

**[125] Ethernet Test Transmission Cycle**

Default (000000)

Valid range: 000000 - 999999 minutes.

**Cellular Receiver 1 Options****[200] Cellular Receiver 1 Enabled** [1] – Ethernet Receiver 2 Enable (Default On) [2] – Cellular Receiver 1 Supervision Enable (Default Off)**[201] Cellular Receiver 1 Account Code**

Default (0000000000)

Valid range: 0000000001 - FFFFFFFFEE.

**[202] Cellular Receiver 1 DNIS**

Default (000000) Valid range: 000000 - 0FFFFF.

**[203] Cellular Receiver 1 Address**

Default (000.000.000.000)

**[204] Cellular Receiver 1 Port**

Default (0BF5/3061) Valid range: 0000 - FFFF.

**[205] Cellular Receiver 1 APN**

32 ASCII characters.

**[206] Cellular Receiver 1 Domain Name**

32 ASCII characters.

**[207] Cellular Receiver 1 Supervision Interval**

Default (0087/135 seconds) Valid Range: 000A-FFFF

**Cellular Receiver 2 Options****[210] Cellular Receiver 2 Enabled** [1] – Cellular Receiver 2 Enable (Default On) [2] – Cellular Receiver 2 Supervision Enable (Default Off)**[211] Cellular Receiver 2 Account Code**

Default (0000000000)

Valid range: 0000000001 - FFFFFFFFEE.

**[212] Cellular Receiver 2 DNIS**

Default (000000)

Valid range: 000000 - 0FFFFF.

**[213] Cellular Receiver 2 Address**

Default (000.000.000.000)

**[214] Cellular Receiver 2 Port**

Default (0BF5/3061) Valid range: 0000 - FFFF.

**[215] Cellular Receiver 2 APN**

Default ( ) 32 ASCII characters.

**[216] Cellular Receiver 2 Domain Name**

Default ( ) 32 ASCII characters.

**[217] Cellular Receiver 2 Supervision Interval**

Default (0087/135 seconds)

Valid Range 000A – FFFF

**Cellular Options****[221] Cellular Public Access Point Name**

Default ( ) 32 ASCII characters

**[222] Cellular Login User Name**

Default ( ) 32 ASCII characters.

**[223] Cellular Login Password**

Default ( ) 32 ASCII characters.

**[224] Cellular Test Transmission Time of Day**

Default (9999)

Valid range: 00 - 23 hrs. (HH) 00 - 59 min. (MM).

**[225] Cellular Test Transmission Cycle**

Default (000000)

Valid range: 000000 - 999999 minutes.

**[226] Network Trouble Delay**

Default (0F)

Valid entries from 00 to FF.

**[227] Voice Call Timeout**

Default (00)

Valid entries from 00 to FF.

**[228] Voice Call Back Time**

Default (0A)

Valid entries from 00 to FF.

**[229] Voice Call Back Number**

---

**[237] Primary Cellular DNS IP**

Default (000.000.000.000)

**[238] Backup Cellular DNS IP**

Default (000.000.000.000)

**Command and Control Options**

**[301] Command and Control Toggle Options**

- [1] SMS Notification (ON)
- [2] Serial Communication Port enabled (OFF)
- [3] SMS Command and Control Default (ON)
- [4] Interactive (OFF)
- [5] SMS Character Format (OFF)
- [6] Long SMS Message Handling Default (OFF)
- [7] Reserved
- [8] Reserved

**[308] Outgoing SMS Retry Attempts**

Default (19) Valid entries from, 00 to FF.

**[309] Outgoing SMS Retry Counter**

Default (000F) Valid entry: 0000 - FFFF.

**[311]-[342] SMS Phone Number 1-32**

---

**[343]-[374] SMS Phone Number 1-32 Toggle Options**

- [1] SMS Notification Alarm/Restore Default (ON).
- [2] SMS Notification Tamper/Restore Default (ON)
- [3] SMS Notification Opening/Closing Default (ON)
- [4] SMS Notification System Maintenance Default (ON)
- [5] SMS Notification System Test Default (ON)
- [6] SMS Notification Internal Events Default (ON).

[7] SMS Notification Enabled Default (ON).

[8] SMS Command and Control Enabled Default (ON)

**[375]-[406] SMS Phone Number 1-32 Partition Assignment**

Default (00) Valid range: 00 - FF.

00 - Global; 01-32 - Partition; FF - Disabled

**[420] Serial Port Baud Rate ('R' models only)**

Default (05)

01=9600 Baud; 02=19200 Baud; 03=38400 Baud;  
04=57600 Baud; 05=115200 Baud

**[421] Serial Port Settings ('R' models only)**

- [1] Parity Enabled (OFF)
- [2] Parity Type (OFF-Even Parity)
- [3] 2 Stop Bits (OFF-1 Stop Bit)
- [4] Flow Control (OFF)

**[422] Integration Identification Number**

**[423] Session 1 Integration Access Code**

Default (12345678) Valid range: 00000000 - FFFFFFFF

**[424] Session 1 SMS Label**

Default (11111111)

---

**[425] Session 1 Integration Toggle Options 2**

- [1] Integration Over Serial Port (ON)
- [2] Integration Over Cellular (OFF)
- [3] Integration Over Ethernet (OFF)
- [4] Type 2 Encryption (OFF)
- [5] Integration Protocol (ON)
- [6] Interactive Protocol SMA (OFF)
- [7] Reserved
- [8] Interactive Encryption for SMA (ON)

**[426] Session 1 Integration Toggle Options 3**

- [1] UDP Polling (OFF)
- [2] TCP Polling (OFF)
- [3] Real-time Notification (OFF)
- [4] Notification Follows Poll (OFF)
- [5] Reserved
- [6] Reserved
- [7] Reserved
- [8] Reserved

**[427] Session 1 Interactive Polling Interval**

Default (000A) Valid range: 0000 - FFFF seconds.

**[428] Session 1 Integration Server IP**

Default (000.000.000.000)

--	--	--	--	--	--	--	--	--	--	--	--	--	--	--	--	--	--	--	--

**[429] Session 1 Integration Notification Port**

Default (0C00/3072) Valid range: 0000 - FFFF.

--	--	--	--	--	--

**[430] Session 1 Integration Polling Port**

Default (0C01/3073) Valid range: 0000 - FFFF.

--	--	--	--	--	--

**[431] Session 1 Integration Server DNS**

32 ASCII characters.

**[432] Session 1 Integration Outgoing Port**

Default (0C04/3076) Valid range: 0000 - FFFF.

--	--	--	--	--	--

**[433] Session 1 Integration Incoming Port**

Default (0BFF/3071) Valid range: 0000 - FFFF.

--	--	--	--	--	--

**[434] Session 1 Notification Zone 1-8 Toggle**

- [1] Zone 1 Default (ON)
- [2] Zone 2 Default (ON)
- [3] Zone 3 Default (ON)
- [4] Zone 4 Default (ON)
- [5] Zone 5 Default (ON)
- [6] Zone 6 Default (ON)
- [7] Zone 7 Default (ON)
- [8] Zone 8 Default (ON)

**[435] Session 1 Notification Zone 9-16 Toggle**

- [1] Zone 9 Default (ON)
- [2] Zone 10 Default (ON)
- [3] Zone 11 Default (ON)
- [4] Zone 12 Default (ON)
- [5] Zone 13 Default (ON)
- [6] Zone 14 Default (ON)
- [7] Zone 15 Default (ON)
- [8] Zone 16 Default (ON)

**[436] Session 1 Notification Zone 17-24 Toggle**

- [1] Zone 17 Default (ON)
- [2] Zone 18 Default (ON)
- [3] Zone 19 Default (ON)
- [4] Zone 20 Default (ON)
- [5] Zone 21 Default (ON)
- [6] Zone 22 Default (ON)
- [7] Zone 23 Default (ON)
- [8] Zone 24 Default (ON)

**[437] Session 1 Notification Zone 25-32 Toggle**

- [1] Zone 25 Default (ON)
- [2] Zone 26 Default (ON)
- [3] Zone 27 Default (ON)
- [4] Zone 28 Default (ON)
- [5] Zone 29 Default (ON)
- [6] Zone 30 Default (ON)
- [7] Zone 31 Default (ON)
- [8] Zone 32 Default (ON)

**[438] Session 1 Notification Zone 33-40 Toggle**

- [1] Zone 33 Default (ON)
- [2] Zone 34 Default (ON)
- [3] Zone 35 Default (ON)
- [4] Zone 36 Default (ON)
- [5] Zone 37 Default (ON)
- [6] Zone 38 Default (ON)
- [7] Zone 39 Default (ON)
- [8] Zone 40 Default (ON)

**[439] Session 1 Notification Zone 41-48 Toggle**

- [1] Zone 41 Default (ON)
- [2] Zone 42 Default (ON)
- [3] Zone 43 Default (ON)
- [4] Zone 44 Default (ON)
- [5] Zone 45 Default (ON)
- [6] Zone 46 Default (ON)
- [7] Zone 47 Default (ON)
- [8] Zone 48 Default (ON)

**[440] Session 1 Notification Zone 49-56 Toggle**

- [1] Zone 49 Default (ON)
- [2] Zone 50 Default (ON)
- [3] Zone 51 Default (ON)
- [4] Zone 52 Default (ON)
- [5] Zone 53 Default (ON)
- [6] Zone 54 Default (ON)
- [7] Zone 55 Default (ON)
- [8] Zone 56 Default (ON)

**[441] Session 1 Notification Zone 57-64 Toggle**

- [1] Zone 57 Default (ON)
- [2] Zone 58 Default (ON)
- [3] Zone 59 Default (ON)
- [4] Zone 60 Default (ON)
- [5] Zone 61 Default (ON)
- [6] Zone 62 Default (ON)
- [7] Zone 63 Default (ON)
- [8] Zone 64 Default (ON)



**[701] Session 2 (Type 2) Integration Access Code**

Default (12345678123456781234567812345678)

Valid range: (00000000000000000000000000000000 - FFFFFFFFFFFFFFFFFFFFFFFFFFFFFFFFFF)

**[708] Event Report Retry Interval**

Default (0A14285000000000)

Valid range: 0000000000000000 - FFFFFFFFFFFFFFFF.

**[709] Event Report Retry Timeout**

Default (0000012C) Valid range: 00000000 - FFFFFFFF.

**[710] Lifestyle Event Log Sync Timeout**

Default (00015180) Valid range: 00000000 - FFFFFFFF.

**[711] Integration Inactivity Timeout**

Default (0000012C) Valid range: 00000000 - FFFFFFFF.

**[716] Lifestyle Reset Window**

Default (0E10) Valid range: 0000 - FFFF.

**[720] Local debug TCP Port**

Default (0000) Valid range: 0000 - FFFF.

**[722] Lifestyle Zone 1-8 Toggle**

- [1] Zone 1 Default (ON)
- [2] Zone 2 Default (ON)
- [3] Zone 3 Default (ON)
- [4] Zone 4 Default (ON)
- [5] Zone 5 Default (ON)
- [6] Zone 6 Default (ON)
- [7] Zone 7 Default (ON)
- [8] Zone 8 Default (ON)

**[723] Lifestyle Zone 9-16 Toggle**

- [1] Zone 9 Default (ON)
- [2] Zone 10 Default (ON)
- [3] Zone 11 Default (ON)
- [4] Zone 12 Default (ON)
- [5] Zone 13 Default (ON)
- [6] Zone 14 Default (ON)
- [7] Zone 15 Default (ON)
- [8] Zone 16 Default (ON)

**[724] Lifestyle Zone 17-24 Toggle**

- [1] Zone 17 Default (ON)
- [2] Zone 18 Default (ON)

- [3] Zone 19 Default (ON)
- [4] Zone 20 Default (ON)
- [5] Zone 21 Default (ON)
- [6] Zone 22 Default (ON)
- [7] Zone 23 Default (ON)
- [8] Zone 24 Default (ON)

**[725] Lifestyle Zone 25-32 Toggle**

- [1] Zone 25 Default (ON)
- [2] Zone 26 Default (ON)
- [3] Zone 27 Default (ON)
- [4] Zone 28 Default (ON)
- [5] Zone 29 Default (ON)
- [6] Zone 30 Default (ON)
- [7] Zone 31 Default (ON)
- [8] Zone 32 Default (ON)

**[726] Lifestyle Zone 33-40 Toggle**

- [1] Zone 33 Default (ON)
- [2] Zone 34 Default (ON)
- [3] Zone 35 Default (ON)
- [4] Zone 36 Default (ON)
- [5] Zone 37 Default (ON)
- [6] Zone 38 Default (ON)
- [7] Zone 39 Default (ON)
- [8] Zone 40 Default (ON)

**[727] Lifestyle Zone 41-48 Toggle**

- [1] Zone 41 Default (ON)
- [2] Zone 42 Default (ON)
- [3] Zone 43 Default (ON)
- [4] Zone 44 Default (ON)
- [5] Zone 45 Default (ON)
- [6] Zone 46 Default (ON)
- [7] Zone 47 Default (ON)
- [8] Zone 48 Default (ON)

**[728] Lifestyle Zone 49-56 Toggle**

- [1] Zone 49 Default (ON)
- [2] Zone 50 Default (ON)
- [3] Zone 51 Default (ON)
- [4] Zone 52 Default (ON)
- [5] Zone 53 Default (ON)
- [6] Zone 54 Default (ON)
- [7] Zone 55 Default (ON)
- [8] Zone 56 Default (ON)

**[729] Lifestyle Zone 57-64 Toggle**

- [1] Zone 57 Default (ON)

- [2] Zone 58 Default (ON)
- [3] Zone 59 Default (ON)
- [4] Zone 60 Default (ON)
- [5] Zone 61 Default (ON)
- [6] Zone 62 Default (ON)
- [7] Zone 63 Default (ON)
- [8] Zone 64 Default (ON)

**[730] Lifestyle Zone 65-72 Toggle**

- [1] Zone 65 Default (ON)
- [2] Zone 66 Default (ON)
- [3] Zone 67 Default (ON)
- [4] Zone 68 Default (ON)
- [5] Zone 69 Default (ON)
- [6] Zone 70 Default (ON)
- [7] Zone 71 Default (ON)
- [8] Zone 72 Default (ON)

**[731] Lifestyle Zone 73-80 Toggle**

- [1] Zone 73 Default (ON)
- [2] Zone 74 Default (ON)
- [3] Zone 75 Default (ON)
- [4] Zone 76 Default (ON)
- [5] Zone 77 Default (ON)
- [6] Zone 78 Default (ON)
- [7] Zone 79 Default (ON)
- [8] Zone 80 Default (ON)

**[732] Lifestyle Zone 81-88 Toggle**

- [1] Zone 81 Default (ON)
- [2] Zone 82 Default (ON)
- [3] Zone 83 Default (ON)
- [4] Zone 84 Default (ON)
- [5] Zone 85 Default (ON)
- [6] Zone 86 Default (ON)
- [7] Zone 87 Default (ON)
- [8] Zone 88 Default (ON)

**[733] Lifestyle Zone 89-96 Toggle**

- [1] Zone 89 Default (ON)
- [2] Zone 90 Default (ON)
- [3] Zone 91 Default (ON)
- [4] Zone 92 Default (ON)
- [5] Zone 93 Default (ON)
- [6] Zone 94 Default (ON)
- [7] Zone 95 Default (ON)
- [8] Zone 96 Default (ON)

**[734] Lifestyle Zone 97-104 Toggle**

- [1] Zone 97 Default (ON)
- [2] Zone 98 Default (ON)
- [3] Zone 99 Default (ON)
- [4] Zone 100 Default (ON)
- [5] Zone 101 Default (ON)
- [6] Zone 102 Default (ON)
- [7] Zone 103 Default (ON)
- [8] Zone 104 Default (ON)

**[735] Lifestyle Zone 105-112 Toggle**

- [1] Zone 105 Default (ON)
- [2] Zone 106 Default (ON)
- [3] Zone 107 Default (ON)
- [4] Zone 108 Default (ON)
- [5] Zone 109 Default (ON)
- [6] Zone 110 Default (ON)
- [7] Zone 111 Default (ON)
- [8] Zone 112 Default (ON)

**[736] Lifestyle Zone 113-120 Toggle**

- [1] Zone 113 Default (ON)
- [2] Zone 114 Default (ON)
- [3] Zone 115 Default (ON)
- [4] Zone 116 Default (ON)
- [5] Zone 117 Default (ON)
- [6] Zone 118 Default (ON)
- [7] Zone 119 Default (ON)
- [8] Zone 120 Default (ON)

**[737] Lifestyle Zone 121-128 Toggle**

- [1] Zone 121 Default (ON)
- [2] Zone 122 Default (ON)
- [3] Zone 123 Default (ON)
- [4] Zone 124 Default (ON)
- [5] Zone 125 Default (ON)
- [6] Zone 126 Default (ON)
- [7] Zone 127 Default (ON)
- [8] Zone 128 Default (ON)

**External Event Label Programming**

**[738] Burglary Alarm**

Default (Burglary Alarm)

---

**[739] Burglary Alarm Restore**

Default (Burglary Alarm Restore)

---

**[740] Fire Alarm**

Default (Fire Alarm)

---

---

**[741] Fire Alarm Restore**

Default (Fire Alarm Restore)

---

**[742] 24 Hour Alarm**

Default (24 Hour Alarm)

---

**[743] 24 Hour Alarm Restore**

Default (24 Hour Alarm Restore)

---

**[744] Holdup Alarm**

Default (Holdup Alarm)

---

**[745] Holdup Alarm Restore**

Default (Holdup Alarm Restore)

---

**[746] Gas Alarm**

Default (Gas Alarm)

---

**[747] Gas Alarm Restore**

Default (Gas Alarm Restore)

---

**[748] High Temperature Alarm**

Default (High Temperature Alarm)

---

**[749] High Temperature Alarm Restore**

Default (High Temperature Alarm Restore)

---

**[750] Medical Alarm**

Default (Medical Alarm)

---

**[751] Medical Alarm Restore**

Default (Medical Alarm Restore)

---

**[752] Panic Alarm**

Default (Panic Alarm)

---

**[753] Panic Alarm Restore**

Default (Panic Alarm Restore)

---

**[754] Emergency Alarm**

Default (Emergency Alarm)

---

**[755] Emergency Alarm Restore**

Default (Emergency Alarm Restore)

---

**[756] Sprinkler Alarm**

Default (Sprinkler Alarm)

---

**[757] Sprinkler Alarm Restore**

Default (Sprinkler Alarm Restore)

---

**[758] Water Level Alarm**

Default (Water Level Alarm)

---

---

**[759] Water Level Alarm Restore**

Default (Water Level Alarm Restore)

---

**[760] Low Temperature Alarm**

Default (Low Temperature Alarm)

---

**[761] Low Temperature Alarm Restore**

Default (Low Temperature Alarm Restore)

---

**[762] Fire Supervisory**

Default (Fire Supervisory)

---

**[763] Fire Supervisory Restore**

Default (Fire Supervisory Restore)

---

**[764] CO Alarm**

Default (CO Alarm)

---

**[765] CO Alarm Restore**

Default (CO Alarm Restore)

---

**[766] Water Alarm**

Default (Flood Alarm)

---

**[767] Water Alarm Restore**

Default (Flood Alarm Restore)

---

**[768] Quick Bypass Alarm**

Default (Quick Bypass Alarm)

---

**[769] Quick Bypass Alarm Restore**

Default (Quick Bypass Alarm Restore)

---

**[770] Aux Alarm**

Default (Aux Alarm)

---

**[771] Aux Alarm Restore**

Default (Aux Alarm Restore)

---

**[772] Zone Expander Supervisory Alarm**

Default (Zone Expander Supervisory Alarm)

---

**[773] Zone Expander Supervisory Alarm Restore**

Default (Zone Expander Supervisory Alarm Restore)

---

**[774] Duress Alarm**

Default (Duress Alarm)

---

**[775] Account Label**

Default (Security System)

---

---

**[776] General System Tamper**

Default (General System Tamper)

---

**[777] General System Tamper Restore**

Default (General System Tamper Restore)

---

**[778] General System Trouble**

Default (General System Trouble)

---

**[779] General System Restore**

Default (General System Restore)

---

**[780] Panel AC Power Trouble Label**

Default (AC Power Trouble)

---

**[781] Panel AC Power Restore Label**

Default (AC Power Restore)

---

**[782] Panel Auxiliary Power Trouble**

Default (Auxiliary Power Trouble)

---

**[783] Panel Auxiliary Power Restore**

Default (Auxiliary Power Restore)

---

**[784] Panel Battery Trouble**

Default (Battery Trouble)

---

**[785] Panel Battery Restore**

Default (Battery Trouble Restore)

---

**[786] Panel Bell Circuit Trouble**

Default (Bell Circuit Trouble)

---

**[787] Panel Bell Circuit Restore**

Default (Bell Circuit Restore)

---

**[788] Panel Telephone Line Trouble**

Default (Telephone Line Failure)

---

**[789] Panel Telephone Line Restore**

Default (Telephone Line Restore)

---

**[790] Fail to Communicate Trouble**

Default (Fail to Communicate Trouble)

---

**[791] Fail to Communicate Restore**

Default (Fail to Communicate Restore)

---

**[792] Fire Trouble**

Default (Fire Trouble)

---

**[793] Fire Trouble Restore**

Default (Fire Trouble Restore)

---

---

**[794] Zone Tamper**

Default (Zone Tamper)

---

**[795] Zone Tamper Restore**

Default (Zone Tamper Restore)

---

**[796] Zone Fault**

Default (Zone Fault)

---

**[797] Zone Fault Restore**

Default (Zone Fault Restore)

---

**[798] Alternate Communicator Trouble**

Default (Alternate Communicator Trouble)

---

**[799] Alternate Communicator Restore**

Default (Alternate Communicator Restore)

---

**[800] Module Trouble**

Default (Module Trouble)

---

**[801] Module Trouble Restore**

Default (Module Trouble Restore)

---

**[802] Wireless/AML Device Trouble**

Default (Device Trouble)

---

**[803] Wireless/AML Device Restore**

Default (Device Trouble Restore)

---

**[804] Disarmed By**

Default (Disarmed By)

---

**[805] Armed By**

Default (Armed By)

---

**[806] Disarmed**

Default (Disarmed)

---

**[807] Armed**

Default (Armed)

---

**[808] Automatic Disarming**

Default (Automatic Disarming)

---

**[809] Automatic Arming**

Default (Automatic Arming)

---

**[810] Automatic Arming Cancelled**

Default (Automatic Arming Cancelled)

---

---

**[811] Late to Open**

Default (Late to Open)

---

**[812] Late to Close**

Default (Late to Close)

---

**[813] Disarmed After Alarm**

Default (Disarmed After Alarm)

---

**[814] Alarm Occurred After Arming**

Default (Alarm Occurred After Arming)

---

**[815] Exit Fault**

Default (Exit Fault)

---

**[816] Cold Start**

Default (Cold Start)

---

**[817] Armed With Zones Bypassed**

Default (Armed With Zones Bypassed)

---

**[818] Zone Bypassed**

Default (Zone Bypassed)

---

**[819] Zone Unbypassed**

Default (Zone Unbypassed)

---

**[820] Burglary Verified**

Default (Burglary Verified)

---

**[821] Burglary Not Verified**

Default (Burglary Not Verified)

---

**[822] Alarm Cancelled**

Default (Alarm Cancelled)

---

**[823] Holdup Verified**

Default (Holdup Verified)

---

**[824] Walk Test Begin**

Default (Walk Test Begin)

---

**[825] Walk Test End**

Default (Walk Test End)

---

**[826] System Test**

Default (Test Message)

---

**[827] Periodic Test Transmission**

Default (Periodic Test)

---

**[828] Periodic Test With Trouble**

Default (Periodic Test With Trouble)

---

---

**[829] DLS Remote Programming Begin**

Default (Remote Programming Begin)

---

**[830] DLS Remote Programming End**

Default (Remote Programming End)

---

**[831] SA Remote Programming Begin**

Default (Remote Programming Begin)

---

**[832] SA Remote Programming End**

Default (Remote Programming End)

---

**[833] Installer Lead In**

Default (Local Programming Begin)

---

**[834] Installer Lead Out**

Default (Local Programming End)

---

**[835] Firmware Update Begin**

Default (Firmware Update Begin)

---

**[836] Firmware Update Successful**

Default (Firmware Update Successful)

---

**[837] Firmware Update Fail**

Default (Firmware Update Fail)

---

**[838] Delinquency**

Default (Delinquency)

---

**[839] Keypad Lockout**

Default (Keypad Lockout)

---

**[840] Event Log 75% full**

Default (Event Log Near Full)

---

**[841] FTC Trouble**

Default (fail to communicate trouble)

---

**[842] FTC Restore**

Default (fail to communicate restore)

---

**[843] Panel Absent Trouble**

Default (Panel Communications Trouble)

---

**[844] Panel Absent Trouble Restore**

Default (Panel Communications Restore)

---

**[845] Module Reprogramming**

Default (Communicator Programming Updated)

---

---

**[846] Firmware Update**

Default (Communicator Programming Updated)

---

**[850] Module**

Default (Module)

---

**[851] Stay Arm**

Default (Stay Arm)

---

**[852] Away Arm**

Default (Away Arm)

---

**[853] Night Arm**

Default (Night Arm)

---

**[854] Disarm**

Default (Disarm)

---

**[855] Activate Command Output 1**

Default (Activate Command Output 1)

---

**[856] Activate Command Output 2**

Default (Activate Command Output 2)

---

**[857] Activate Command Output 3**

Default (Activate Command Output 3)

---

**[858] Activate Command Output 4**

Default (Activate Command Output 4)

---

**[859] Deactivate Command Output 1**

Default (Deactivate Command Output 1)

---

**[860] Deactivate Command Output 2**

Default (Deactivate Command Output 2)

---

**[861] Deactivate Command Output 3**

Default (Deactivate Command Output 3)

---

**[862] Deactivate Command Output 4**

Default (Deactivate Command Output 4)

---

**[863] Bypass**

Default (Bypass)

---

**[864] Unbypass**

Default (Unbypass)

---

**[865] Status Request**

Default (Status Request)

---

**[866] Alarm Memory Request**

Default (Alarm Memory Request)

---

---

**[867] Help**

Default (Help)

---

**[868] Pay As You Go Balance Request**

Default (Balance Request)

---

**[869] Keypad Message**

Default (Keypad Message)

---

**[870] Function Successful**

Default (Successful)

---

**[871] Function Failure**

Default (Unsuccessful)

---

**[872] Invalid Command**

Default (Invalid Command)

---

**[873] System Stay Armed**

Default (Stay Armed)

---

**[874] System Away Armed**

Default (Away Armed)

---

**[875] System Night Armed**

Default (Night Armed)

---

**[876] System Disarmed Ready**

Default (Disarmed Ready)

---

**[877] System Disarmed, Not Ready**

Default (Disarmed Not Ready)

---

**[878] System In Alarm**

Default (is in Alarm)

---

**[879] Trouble Label**

Default (Service is Required)

---

**[880] No Alarms in Memory**

Default (No Alarms in Memory)

---

**[881] Pay As You Go Balance**

Default (Pay as you go balance:)

---

**[882] Pay As You Go Message**

Default (\*123#)

---

**[883] Response Code**

Default (Response Code)

---



# Limited Warranty

Digital Security Controls ("DSC"), a division of Tyco Safety Products Canada Ltd, a part of the Johnson Controls group of companies ("JCI"), warrants the original purchaser that for a period of twelve months from the date of purchase, the product shall be free of defects in materials and workmanship under normal use. During the warranty period, JCI shall, at its option, repair or replace any defective product upon return of the product to its factory, at no charge for labour and materials. Any replacement and/or repaired parts are warranted for the remainder of the original warranty or ninety (90) days, whichever is longer. The original purchaser must promptly notify JCI in writing that there is a defect in material or workmanship, such written notice to be received in all events prior to expiration of the warranty period. There is absolutely no warranty on software and all software products are sold as a user license under the terms of the software license agreement included with the product. The Customer assumes all responsibility for the proper selection, installation, operation and maintenance of any products purchased from JCI. Custom products are only warranted to the extent that they do not function upon delivery. In such cases, JCI can replace or credit at its option.

## International Warranty

The warranty for international customers is the same as for any customer within Canada and the United States, with the exception that JCI shall not be responsible for any customs fees, taxes, or VAT that may be due.

## Warranty Procedure

To obtain service under this warranty, please return the item(s) in question to the point of purchase. All authorized distributors and dealers have a warranty program. Anyone returning goods to JCI must first obtain an authorization number. JCI will not accept any shipment whatsoever for which prior authorization has not been obtained.

## Conditions to Void Warranty

This warranty applies only to defects in parts and workmanship relating to normal use. It does not cover:

- damage incurred in shipping or handling;
- damage caused by disaster such as fire, flood, wind, earthquake or lightning;
- damage due to causes beyond the control of JCI such as excessive voltage, mechanical shock or water damage;
- damage caused by unauthorized attachment, alterations, modifications or foreign objects;
- damage caused by peripherals (unless such peripherals were supplied by JCI.);
- defects caused by failure to provide a suitable installation environment for the products;
- damage caused by use of the products for purposes other than those for which it was designed;
- damage from improper maintenance;
- damage arising out of any other abuse, mishandling or improper application of the products.

## Items Not Covered by Warranty

In addition to the items which void the Warranty, the following items shall not be covered by Warranty: (i) freight cost to the repair centre; (ii) products which are not identified with JCI's product label and lot number or serial number; (iii) products disassembled or repaired in such a manner as to adversely affect performance or prevent adequate inspection or testing to verify any warranty claim. Access cards or tags returned for replacement under warranty will be credited or replaced at JCI's option. Products not covered by this warranty, or otherwise out of warranty due to age, misuse, or damage shall be evaluated, and a repair estimate shall be provided. No repair work will be performed until a valid purchase order is received from the Customer and a Return Merchandise Authorization number (RMA) is issued by JCI's Customer Service.

JCI's liability for failure to repair the product under this warranty after a reasonable number of attempts will be limited to a replacement of the product, as the exclusive remedy for breach of warranty. Under no circumstances shall JCI be liable for any special, incidental, or consequential damages based upon breach of warranty, breach of contract, negligence, strict liability, or any other legal theory. Such damages include, but are not limited to, loss of profits, loss of the product or any associated equipment, cost of capital, cost of substitute or replacement equipment, facilities or services, down time, purchaser's time, the claims of third parties, including customers, and injury to property. The laws of some jurisdictions limit or do not allow the disclaimer of consequential damages. If the laws of such a jurisdiction apply to any claim by or against JCI, the limitations and disclaimers contained here shall be to the greatest extent permitted by law. Some states do not allow the exclusion or limitation of incidental or consequential damages, so that the above may not apply to you.

## Disclaimer of Warranties

This warranty contains the entire warranty and shall be in lieu of any and all other warranties, whether expressed or implied (including all implied warranties of merchantability or fitness for a particular purpose) and of all other obligations or liabilities on the part of JCI. JCI neither assumes responsibility for, nor authorizes any other person purporting to act on its behalf to modify or to change this warranty, nor to assume for it any other warranty or liability concerning this product. This disclaimer of warranties and limited warranty are governed by the laws of the province of Ontario, Canada.

JCI recommends that the entire system be completely tested on a regular basis. However, despite frequent testing, and due to, but not limited to, criminal tampering or electrical disruption, it is possible for this product to fail to perform as expected.

## Installer's Lockout

Any products returned to DSC which have the Installer's Lockout option enabled and exhibit no other problems will be subject to a service charge.

## Out of Warranty Repairs

JCI will at its option repair or replace out-of-warranty products which are returned to its factory according to the following conditions. Anyone returning goods to JCI must first obtain an authorization number. JCI will not accept any shipment whatsoever for which prior authorization has not been obtained.

Products which JCI determines to be repairable will be repaired and returned. A set fee which JCI has pre-determined and which may be revised from time to time, will be charged for each unit repaired.

Products which JCI determines not to be repairable will be replaced by the nearest equivalent product available at that time. The current market price of the replacement product will be charged for each replacement unit.

## Note to Installers

This warning contains vital information. As the only individual in contact with system users, it is your responsibility to bring each item in this warning to the attention of the users of this system.

## System Failures

This system has been carefully designed to be as effective as possible. There are circumstances, however, involving fire, burglary, or other types of emergencies where it may not provide protection. Any alarm system of any type may be compromised deliberately or may fail to operate as expected for a variety of reasons. Some but not all of these reasons may be:

## Inadequate Installation

A security system must be installed properly in order to provide adequate protection. Every installation should be evaluated by a security professional to ensure that all access points and areas are covered. Locks and latches on windows and doors must be secure and operate as intended. Windows, doors, walls, ceilings and other building materials must be of sufficient strength and construction to provide the level of protection expected. A re-evaluation must be done during and after any construction activity. An evaluation by the fire and/or police department is highly recommended if this service is available.

### **Criminal Knowledge**

This system contains security features which were known to be effective at the time of manufacture. It is possible for persons with criminal intent to develop techniques which reduce the effectiveness of these features. It is important that a security system be reviewed periodically to ensure that its features remain effective and that it be updated or replaced if it is found that it does not provide the protection expected.

### **Access by Intruders**

Intruders may enter through an unprotected access point, circumvent a sensing device, evade detection by moving through an area of insufficient coverage, disconnect a warning device, or interfere with or prevent the proper operation of the system.

### **Power Failure**

Control units, intrusion detectors, smoke detectors and many other security devices require an adequate power supply for proper operation. If a device operates from batteries, it is possible for the batteries to fail. Even if the batteries have not failed, they must be charged, in good condition and installed correctly. If a device operates only by AC power, any interruption, however brief, will render that device inoperative while it does not have power. Power interruptions of any length are often accompanied by voltage fluctuations which may damage electronic equipment such as a security system. After a power interruption has occurred, immediately conduct a complete system test to ensure that the system operates as intended.

### **Failure of Replaceable Batteries**

This system's wireless transmitters have been designed to provide several years of battery life under normal conditions. The expected battery life is a function of the device environment, usage and type. Ambient conditions such as high humidity, high or low temperatures, or large temperature fluctuations may reduce the expected battery life. While each transmitting device has a low battery monitor which identifies when the batteries need to be replaced, this monitor may fail to operate as expected. Regular testing and maintenance will keep the system in good operating condition.

### **Compromise of Radio Frequency (Wireless) Devices**

Signals may not reach the receiver under all circumstances which could include metal objects placed on or near the radio path or deliberate jamming or other inadvertent radio signal interference.

### **System Users**

A user may not be able to operate a panic or emergency switch possibly due to permanent or temporary physical disability, inability to reach the device in time, or unfamiliarity with the correct operation. It is important that all system users be trained in the correct operation of the alarm system and that they know how to respond when the system indicates an alarm.

### **Smoke Detectors**

Smoke detectors that are a part of this system may not properly alert occupants of a fire for a number of reasons, some of which follow. The smoke detectors may have been improperly installed or positioned. Smoke may not be able to reach the smoke detectors, such as when the fire is in a chimney, walls or roofs, or on the other side of closed doors. Smoke detectors may not detect smoke from fires on another level of the residence or building. Every fire is different in the amount of smoke produced and the rate of burning. Smoke detectors cannot sense all types of fires equally well. Smoke detectors may not provide timely warning of fires caused by carelessness or safety hazards such as smoking in bed, violent explosions, escaping gas, improper storage of flammable materials, overloaded electrical circuits, children playing with matches or arson. Even if the smoke detector operates as intended, there may be circumstances when there is insufficient warning to allow all occupants to escape in time to avoid injury or death.

### **Motion Detectors**

Motion detectors can only detect motion within the designated areas as shown in their respective installation instructions. They cannot discriminate between intruders and intended occupants. Motion detectors do not provide volumetric area protection. They have multiple beams of detection and motion can only be detected in unobstructed areas covered by these beams. They cannot detect motion which occurs behind walls, ceilings, floor, closed doors, glass partitions, glass doors or windows. Any type of tampering whether intentional or unintentional such as masking, painting, or spraying of any material on the lenses, mirrors, windows or any other part of the detection system will impair its proper operation. Passive infrared motion detectors operate by sensing changes in temperature. However, their effectiveness can be reduced when the ambient temperature rises near or above body temperature or if there are intentional or unintentional sources of heat in or near the detection area. Some of these heat sources could be heaters, radiators, stoves, barbecues, fireplaces, sunlight, steam vents, lighting and so on.

### **Warning Devices**

Warning devices such as sirens, bells, horns, or strobes may not warn people or awaken someone sleeping if there is an intervening wall or door. If warning devices are located on a different level of the residence or premise, then it is less likely that the occupants will be alerted or awakened. Audible warning devices may be interfered with by other noise sources such as stereos, radios, televisions, air conditioners or other appliances, or passing traffic. Audible warning devices, however loud, may not be heard by a hearing-impaired person.

### **Telephone Lines**

If telephone lines are used to transmit alarms, they may be out of service or busy for certain periods of time. Also, an intruder may cut the telephone line or defeat its operation by more sophisticated means which may be difficult to detect.

### **Insufficient Time**

There may be circumstances when the system will operate as intended, yet the occupants will not be protected from the emergency due to their inability to respond to the warnings in a timely manner. If the system is monitored, the response may not occur in time to protect the occupants or their belongings.

### **Component Failure**

Although every effort has been made to make this system as reliable as possible, the system may fail to function as intended due to the failure of a component.

### **Inadequate Testing**

Most problems that would prevent an alarm system from operating as intended can be found by regular testing and maintenance. The complete system should be tested weekly and immediately after a break-in, an attempted break-in, a fire, a storm, an earthquake, an accident, or any kind of construction activity inside or outside the premises. The testing should include all sensing devices, keypads, consoles, alarm indicating devices and any other operational devices that are part of the system.

### **Security and Insurance**

Regardless of its capabilities, an alarm system is not a substitute for property or life insurance. An alarm system also is not a substitute for property owners, renters, or other occupants to act prudently to prevent or minimize the harmful effects of an emergency situation.

## **EULA**

**IMPORTANT - READ CAREFULLY:** DSC Software purchased with or without Products and Components is copyrighted and is purchased under the following license terms:

This End-User License Agreement ("EULA") is a legal agreement between You (the company, individual or entity who acquired the Software and any related Hardware) and Digital Security Controls, a division of Tyco Safety Products Canada Ltd. ("DSC"), the manufacturer of the integrated security systems and the developer of the software and any related products or components ("HARDWARE") which You acquired.

If the DSC software product ("SOFTWARE PRODUCT" or "SOFTWARE") is intended to be accompanied by HARDWARE, and is NOT accompanied by new HARDWARE, You may not use, copy or install the SOFTWARE PRODUCT. The SOFTWARE PRODUCT includes computer software, and may include associated media, printed materials, and "online" or electronic documentation.

Any software provided along with the SOFTWARE PRODUCT that is associated with a separate end-user license agreement is licensed to You under the terms of that license agreement.

By installing, copying, downloading, storing, accessing or otherwise using the SOFTWARE PRODUCT, You agree unconditionally to be bound by the terms of this EULA, even if this EULA is deemed to be a modification of any previous arrangement or contract. If You do not agree to the terms of this EULA, DSC is unwilling to license the SOFTWARE PRODUCT to You, and You have no right to use it.

## SOFTWARE PRODUCT LICENSE

The SOFTWARE PRODUCT is protected by copyright laws and international copyright treaties, as well as other intellectual property laws and treaties. The SOFTWARE PRODUCT is licensed, not sold.

1. GRANT OF LICENSE This EULA grants You the following rights:

Software Installation and Use - For each license You acquire, You may have only one copy of the SOFTWARE PRODUCT installed.

Storage/Network Use - The SOFTWARE PRODUCT may not be installed, accessed, displayed, run, shared or used concurrently on or from different computers, including a workstation, terminal or other digital electronic device ("Device"). In other words, if You have several workstations, You will have to acquire a license for each workstation where the SOFTWARE will be used.

Backup Copy - You may make back-up copies of the SOFTWARE PRODUCT, but You may only have one copy per license installed at any given time. You may use the back-up copy solely for archival purposes. Except as expressly provided in this EULA, You may not otherwise make copies of the SOFTWARE PRODUCT, including the printed materials accompanying the SOFTWARE.

2. DESCRIPTION OF OTHER RIGHTS AND LIMITATIONS

Limitations on Reverse Engineering, Decompilation and Disassembly - You may not reverse engineer, decompile, or disassemble the SOFTWARE PRODUCT, except and only to the extent that such activity is expressly permitted by applicable law notwithstanding this limitation. You may not make any changes or modifications to the Software, without the written permission of an officer of DSC. You may not remove any proprietary notices, marks or labels from the Software Product. You shall institute reasonable measures to ensure compliance with the terms and conditions of this EULA.

Separation of Components - The SOFTWARE PRODUCT is licensed as a single product. Its component parts may not be separated for use on more than one HARDWARE unit.

Single INTEGRATED PRODUCT - If You acquired this SOFTWARE with HARDWARE, then the SOFTWARE PRODUCT is licensed with the HARDWARE as a single integrated product. In this case, the SOFTWARE PRODUCT may only be used with the HARDWARE as set forth in this EULA.

Rental - You may not rent, lease or lend the SOFTWARE PRODUCT. You may not make it available to others or post it on a server or web site.

Software Product Transfer - You may transfer all of Your rights under this EULA only as part of a permanent sale or transfer of the HARDWARE, provided You retain no copies, You transfer all of the SOFTWARE PRODUCT (including all component parts, the media and printed materials, any upgrades and this EULA), and provided the recipient agrees to the terms of this EULA. If the SOFTWARE PRODUCT is an upgrade, any transfer must also include all prior versions of the SOFTWARE PRODUCT.

Termination - Without prejudice to any other rights, DSC may terminate this EULA if You fail to comply with the terms and conditions of this EULA. In such event, You must destroy all copies of the SOFTWARE PRODUCT and all of its component parts.

Trademarks - This EULA does not grant You any rights in connection with any trademarks or service marks of DSC or its suppliers.

3. COPYRIGHT - All title and intellectual property rights in and to the SOFTWARE PRODUCT (including but not limited to any images, photographs, and text incorporated into the SOFTWARE PRODUCT), the accompanying printed materials, and any copies of the SOFTWARE PRODUCT, are owned by DSC or its suppliers. You may not copy the printed materials accompanying the SOFTWARE PRODUCT. All title and intellectual property rights in and to the content which may be accessed through use of the SOFTWARE PRODUCT are the property of the respective content owner and may be protected by applicable copyright or other intellectual property laws and treaties. This EULA grants You no rights to use such content. All rights not expressly granted under this EULA are reserved by DSC and its suppliers.

4. EXPORT RESTRICTIONS - You agree that You will not export or re-export the SOFTWARE PRODUCT to any country, person, or entity subject to Canadian export restrictions.

5. CHOICE OF LAW - This Software License Agreement is governed by the laws of the Province of Ontario, Canada.

6. ARBITRATION - All disputes arising in connection with this Agreement shall be determined by final and binding arbitration in accordance with the Arbitration Act, and the parties agree to be bound by the arbitrator's decision. The place of arbitration shall be Toronto, Canada, and the installation manual of the arbitration shall be English.

7. LIMITED WARRANTY

NO WARRANTY - DSC PROVIDES THE SOFTWARE "AS IS" WITHOUT WARRANTY. DSC DOES NOT WARRANT THAT THE SOFTWARE WILL MEET YOUR REQUIREMENTS OR THAT OPERATION OF THE SOFTWARE WILL BE UNINTERRUPTED OR ERROR-FREE.

CHANGES IN OPERATING ENVIRONMENT - DSC shall not be responsible for problems caused by changes in the operating characteristics of the HARDWARE, or for problems in the interaction of the SOFTWARE PRODUCT with non-DSC SOFTWARE or HARDWARE PRODUCTS.

LIMITATION OF LIABILITY; WARRANTY REFLECTS ALLOCATION OF RISK - IN ANY EVENT, IF ANY STATUTE IMPLIES WARRANTIES OR CONDITIONS NOT STATED IN THIS LICENSE AGREEMENT, DSC'S ENTIRE LIABILITY UNDER ANY PROVISION OF THIS LICENSE AGREEMENT SHALL BE LIMITED TO THE GREATER OF THE AMOUNT ACTUALLY PAID BY YOU TO LICENSE THE SOFTWARE PRODUCT AND FIVE CANADIAN DOLLARS (CAD\$5.00). BECAUSE SOME JURISDICTIONS DO NOT ALLOW THE EXCLUSION OR LIMITATION OF LIABILITY FOR CONSEQUENTIAL OR INCIDENTAL DAMAGES, THE ABOVE LIMITATION MAY NOT APPLY TO YOU.

DISCLAIMER OF WARRANTIES - THIS WARRANTY CONTAINS THE ENTIRE WARRANTY AND SHALL BE IN LIEU OF ANY AND ALL OTHER WARRANTIES, WHETHER EXPRESSED OR IMPLIED (INCLUDING ALL IMPLIED WARRANTIES OF MERCHANTABILITY OR FITNESS FOR A PARTICULAR PURPOSE) AND OF ALL OTHER OBLIGATIONS OR LIABILITIES ON THE PART OF DSC. DSC MAKES NO OTHER WARRANTIES. DSC NEITHER ASSUMES NOR AUTHORIZES ANY OTHER PERSON PURPORTING TO ACT ON ITS BEHALF TO MODIFY OR TO CHANGE THIS WARRANTY, NOR TO ASSUME FOR IT ANY OTHER WARRANTY OR LIABILITY CONCERNING THIS SOFTWARE PRODUCT.

EXCLUSIVE REMEDY AND LIMITATION OF WARRANTY - UNDER NO CIRCUMSTANCES SHALL DSC BE LIABLE FOR ANY SPECIAL, INCIDENTAL, CONSEQUENTIAL OR INDIRECT DAMAGES BASED UPON BREACH OF WARRANTY, BREACH OF CONTRACT, NEGLIGENCE, STRICT LIABILITY, OR ANY OTHER LEGAL THEORY. SUCH DAMAGES INCLUDE, BUT ARE NOT LIMITED TO, LOSS OF PROFITS, LOSS OF THE SOFTWARE PRODUCT OR ANY ASSOCIATED EQUIPMENT, COST OF CAPITAL, COST OF SUBSTITUTE OR REPLACEMENT EQUIPMENT, FACILITIES OR SERVICES, DOWN TIME, PURCHASER'S TIME, THE CLAIMS OF THIRD PARTIES, INCLUDING CUSTOMERS, AND INJURY TO PROPERTY.

WARNING: DSC recommends that the entire system be completely tested on a regular basis. However, despite frequent testing, and due to, but not limited to, criminal tampering or electrical disruption, it is possible for this SOFTWARE PRODUCT to fail to perform as expected.

## Regulatory Information

### Modification Statement

Digital Security Controls has not approved any changes or modifications to this device by the user. Any changes or modifications could void the user's authority to operate the equipment. *Digital Security Controls n'approuve aucune modification apportée à l'appareil par l'utilisateur, quelle qu'en soit la nature. Tout changement ou modification peuvent annuler le droit d'utilisation de l'appareil par l'utilisateur.*

### Interference Statement

This device complies with Part 15 of the FCC Rules and Industry Canada licence-exempt RSS standard (s). Operation is subject to the following two conditions: (1) this device may not cause interference, and (2) this device must accept any interference, including interference that may cause undesired operation of the device.

*Le présent appareil est conforme aux CNR d'Industrie Canada applicables aux appareils radio exempts de licence. L'exploitation est autorisée aux deux conditions suivantes: (1) l'appareil ne doit pas produire de brouillage, et (2) l'utilisateur de l'appareil doit accepter tout brouillage radioélectrique subi, même si le brouillage est susceptible d'en compromettre le fonctionnement.*

### Wireless Notice

This equipment complies with FCC and IC radiation exposure limits set forth for an uncontrolled environment. The antenna should be installed and operated with minimum distance of 20 cm between the radiator and your body. This transmitter must not be co-located or operating in conjunction with any other antenna or transmitter.

*Cet appareil est conforme aux limites d'exposition aux rayonnements de la IC pour un environnement non contrôlé. L'antenne doit être installée de façon à garder une distance minimale de 20 centimètres entre la source de rayonnements et votre corps. L'émetteur ne doit pas être colocalisé ni fonctionner conjointement avec une autre antenne ou autre émetteur.*

Antenna gain must be below / Gain de l'antenne doit être ci-dessous:

Frequency Band/Bande de fréquence	TL2803GRE, TL2803GE, 3G2080RE, 3G2080E	TL280LE, TL280LER, LE2080, LE2080R
GSM850 / FDD V	2.26 dBi	-
PCS1900 / FDD II	2.41 dBi	-
LTEB2	-	2.76 dBi
LTEB4	-	2.82 dBi
LTEB5 / B12 / B13	-	2.45 dBi

### FCC Class B digital device notice

This equipment has been tested and found to comply with the limits for a Class B digital device, pursuant to part 15 of the FCC Rules. These limits are designed to provide reasonable protection against harmful interference in a residential installation. This equipment generates uses and can radiate radio frequency energy and, if not installed and used in accordance with the instructions, may cause harmful interference to radio communications. However, there is no guarantee that interference will not occur in a particular installation. If this equipment does cause harmful interference to radio or television reception, it can be determined by turning the equipment off and on, the user is encouraged to try to correct the interference by one or more of the following measures:

- Reorient or relocate the receiving antenna.
- Increase the separation between the equipment and receiver.
- Connect the equipment into an outlet on a circuit different from that to which the receiver is connected.
- Consult the dealer or an experienced radio/TV technician for help

### CAN ICES-3 (B) / NMB-3 (B)

**TL2803G(R)E-EU /3G2080(R)E- EU/TL280(R)E LE2080(R)/TL280LE(R)**

FCC ID: F5316 TL2803GRE FCC ID: F5317 TL280LER

IC: 160A-TL2803GRE IC: 160A-TL280LER

### Notes for EN50131-1:2006/A1:2009 Compliant installations:

Models TL2803G(R)E-EU/3G2080(R)E-EU/TL280(R)E/TL280LE-EU/LE2080-EU are an SPT Type Y. The module is mounted within CIE or PSH housing and it receives power from the compatible CIE or Power Supply source that are in compliance with EN50131-6:2017 Type Requirements for a Grade 2, Class II application. This product has no replacement parts and software programmable options are accessible at level 3 (installer mode), section [851]. The TL2803G(R)E-EU/3G2080(R)E-EU/TL280(R)E/TL280LE-EU/LE2080-EU connects to compatible DSC alarm control panels using the DSC proprietary serial interface and protocol PC-Link (converted also to RS-422). The module operates in pass-through mode and it does acknowledge the alarm to the compatible control panel after an acknowledgement has been received from the compatible alarm receiver

1. The TL2803G(R)E-EU/3G2080(R)E-EU/TL280(R)E/TL280LE-EU/LE2080-EU module is monitored by the control panel and it is programmed via the programming menu (\* 8, section [851]) in the control panel. The interface is connected to the PC-Link bus as shown in the diagram included in this manual.
2. The HSPA3G/LTE Cellular path is immune to conducted and radiated RF fields with levels up to 10V/m as tested per EN50130-4 Standard.
3. The TL2803G(R)E-EU/3G2080(R)E-EU/TL280(R)E/TL280LE-EU/LE2080-EU module conforms with radiated emission levels for Class B equipment as per standards EN61000-6-3/EN55022/CISPR32.
4. The TL2803G(R)E-EU/3G2080(R)E-EU/TL280(R)E/TL280LE-EU/LE2080-EU module uses AES128 encryption and heartbeat supervision for HSPA3G/LTE Cellular communication paths and it meets security levels S2 as per EN50136-2:2013. It also uses authentication for each message exchanged with the compatible receiver equipment at ARC and it meets level 2 for information security.
5. The 3G2080(R)E-EU/LE2080-EU module has only one communication path: HSPA3G or LTE Cellular communication path using 900/1800/2100MHz or LTE Public Cellular Network. The HSPA3G/LTE Cellular communication path that can be used in a standalone mode in conjunction with a DSC alarm system (compatible DSC alarm control panel models: HS2128/064/032/016). The supported ATS configuration is: SP4.
6. The TL280(R)E module has only one communication path: Ethernet communication path using Internet. The communication path that can be used in a standalone mode in conjunction with a DSC alarm system (compatible DSC alarm control panel models: HS2128/064/032/016). The supported ATS configuration is: SP4.
7. The TL2803G(R)E-EU/TL280LE-EU module has two communication paths: HSPA3G/LTE Cellular communication path using 900/1800/2100MHz LTE Public Cellular Network and Ethernet communication path using Internet. The communication paths can be used in a standalone mode in conjunction with a DSC alarm system (compatible DSC alarm control panel models: HS2128/064/032/016). The supported ATS configuration is: SP4 or DP3.
8. TL2803G(R)E-EU/3G2080(R)E-EU/TL280(R)E/TL280LE-EU/LE2080-EU has been tested for compliance in conjunction with the following applicable standards: EN50136-1:2012 + A1:2018, EN50136-2:2013, EN50131-1:2014, ATS configuration: SP4, DP3

For EN50131-1:2006/A2:2017 compliant installations, the following programming options shall be set as described. Supervision Heartbeat: shall be set to 180 seconds

ATS Custom Category C	Level
EN50136-1:2012 + A1:2018 Table 2 – Transmission time	SPT according to SP4 and DP3
EN50136-1:2012 + A1:2018 Table 3 – Maximum Reporting Time	SPT according to SSPT according to SP4 and DP3P4 and DP3
EN50136-1:2012 + A1:2018 Table 7 – ATSN availability	SPT according to SP4 and DP3 (depending on cellular carrier used)
EN50136-1:2012 + A1:2018 Table 8 – SPT substitution security requirements	SPT according to SP4 and DP3 (use AES-128 and authentication/sequential information in each message transmitted to the SG receiver)
EN50136-1:2012 + A1:2018 Table 9 – SPT information security requirements	SPT according to SP4 and DP3 (use AES-128 encryption)
EN50136-1:2012 + A1:2018 Table 1 – ATS configuration	Use single communication path for models 3G2080(R)E-EU/LE2080-EU (cellular network), TL280(R)E/Ethernet port) (SPT according to SP4) and two communication paths for model TL2803G (R) E-EU/TL280LE-EU (cell/Ethernet). (SPT according to SP4 or DP3)
EN50136-1:2012 + A1:2018 Table 4 – RCT to AE alarm reporting	ATS failure reported to ARC, SPT according to SP4 and DP3
EN50136-1:2012 + A1:2018 Table 5 – SPT to AS alarm reporting	ATS failure reported to AS (DSC compatible control panel HS2128/HS2064/HS2032/HS2016). SPT according to SP4 and DP3
EN50136-1:2012 + A1:2018 Table 6 – ATS availability recording	There is no recording of availability failure
EN50136-2:2013 Table 1	No logging function provided
EN50136-2:2013 Table 2	No memory provided for logging function
EN50136-2:2013 Table 3	ATS failure reported to ARC

## SIMPLIFIED EU DECLARATION OF CONFORMITY

Hereby, Tyco Safety Products Canada Ltd declares that the radio equipment type is in compliance with Directive 2014/53/EU. The full text of the EU declarations of conformity for the models mentioned below are available at the following internet addresses:

TL2803G(R)E-EU - <http://dsc.com/pdf/1605003>

3G2080(R)E-EU - <http://dsc.com/pdf/1605004>

TL280LE-EU - <http://dsc.com/pdf/2112001>

LE2080-EU - <http://dsc.com/pdf/2112002>

### Operating frequency bands and related max radio-frequency power transmitted:

**NOTE:** The compatible receiver at ARC location shall have supervision window programmed for 180 seconds. TL2803G(R)E-EU/3G2080 (R)E-EU/TL280 (R)E/TL280LE-EU/LE2080-EU has been certified by TELEFICATION in accordance with EN50131-1:2006/A2:2017, EN50131-10:2014 requirements for Grade 2, Class II and EN50136-2:2013 ATS Custom Category C according to SP4 and DP3.

Frequency Band	Maximum Power
EGSM900 880.0MHz-914.8MHz	Class 4 (2W) @ 900MHz, GSM
EGSM900 880.2MHz-889.8MHz	Class 1 (1W) @ 1800MHz, GSM
DCS1800 1710.2MHz-1784.8MHz	Class E2 (0.5W) @ 900MHz, EDGE
WCDMA (Band VIII) 882.4MHz-912.6MHz	Class E2 (0.4W) @ 1800MHz, EDGE
WCDMA2100 (Band I) 1922.4MHz-1977.6MHz	Class 3 (0.25W) @ 900/2100MHz, WCDMA
LTE 25dBm	Class 3 @ 700(FDD28)/800(FDD20)/900 (FDD8)/1800 (FDD3)/2100 (FDD1)/2600 (FDD7) MHz

Only models TL2803GRE-EU, TL2803GE-EU, 3G2080RE-EU, 3G2080E-EU, TL280LE-EU and LE2080-EU are CE compliant.

European single point of contact: Tyco Safety Products, Voltaweg 20, 6101XK, Echt, Netherlands

### UL/ULC Installation Requirements

**NOTE:** For equipment used at the protected premises and intended to facilitate IP communications (hubs, routers, NIDs, Digital Subscriber Line (DSL), cable modems), 24 hour backup power is required. Where such cannot be facilitated, a secondary (back-up) communication channels is required.

**Domain Name Service (DNS) programming is not permitted in UL1610 listed systems.**

#### Technical Specifications

The input voltage to the Communicator can be drawn from the Underwriters Laboratories/Underwriters Laboratories Canada (UL/ULC) listed control panel.

#### Notes for using Private, Corporate, and High Speed Data Networks:

Network access and domain access policies shall be set to restrict unauthorized network access, and spoofing or Denial of Service (DoS) attacks. Select an Internet Service Provider (ISP) that has redundant servers/systems, back-up power, routers with firewalls enabled, and methods to identify and protect against DoS attacks (e.g., via spoofing).

#### Notes for using Public Switched and Cellular Data Networks:

Communication channels shall be facilitated such that the communicator will restrict unauthorized access, which could otherwise compromise security. The communicator shall be located in a secured area.

• For **ULC Residential Fire and Burglary** applications the TL2803G(R)E/3G2080(R)E/TL280(R)E/LE2080(R)(X)/TL280LE(R)(X) can be used as primary communication channel via either cellular or Ethernet or as a back-up in conjunction with the Digital Alarm Communicator Transmitter (DACT).  
 Test transmission every 24 hours shall be enabled on each channel.

• For **ULC Commercial Fire and Burglary** applications the TL2803G(R)E/3G2080(R)E/TL280(R)E/LE2080(R)(X)/TL280LE(R)(X) can be used as a passive communication module with the following security levels:

- P1 (each channel cellular or Ethernet is independent)
- P2 (cellular and Ethernet in back-up configuration, panel section [851][005] toggle option [5] OFF).
- P3 (cellular and Ethernet in redundant configuration, panel section [851][005] toggle option [5] ON).

The communicator can also be used as an active communication system with the security levels A1-A4 (each channel cellular or Ethernet independent or together in a back-up/redundant configuration). For active line security systems AES128 bit encryption shall be enabled (at the monitoring station receiver) and the supervision heartbeat rate shall be set as 90 seconds (panel section [851][004] = 005A/90). The supervision window at the Signal Receiver Center (SRC)'s receiver shall be programmed as maximum of 180 (00B4/180) seconds.

**NOTE:** For ULC commercial fire passive communication, encryption shall be enabled.

• For **UL Residential Fire and Burglary** applications the TL2803G(R)E/3G2080(R)E/TL280(R)E/LE2080(R)(X)/TL280LE(R)(X) can be used as the primary communication channel via either cellular or Ethernet, or as a back-up in conjunction with the DACT (30 day test transmission is required on each channel).

- For **UL Commercial Burglary** applications the **TL2803G(R)E/ 3G2080R / TL280(R)E / LE2080(R)X / TL280LE(R)X** can be used as dual signalling line communication system (cellular and Ethernet channels used in redundant configuration), standard line security and as encrypted line security.
- The supervision heartbeat shall be enabled (panel section [851][005] toggle option [1] (Ethernet) and/or toggle option [2] (cellular) shall be ON), toggle option [3] (supervision type) shall be ON and the supervision heartbeat rate shall be selected as 135 (0087/135) seconds. Option [004] = 0087. The supervision window at the supervising station shall be maximum 200 (00C8/200) seconds. For encrypted line security systems the encryption AES 128 bit shall be enabled at the monitoring station receiver.
- For **UL Commercial Burglary** installations, the **TL2803G(R)E/3G2080 (R)E/TL280(R)E/LE2080 (R)X/TL280LE(R)X** is listed as a primary (sole) communication means (heartbeat must be enabled) or for supplementary (back-up) use in conjunction with a Plain Old Telephone Service (POTS) line dialer. When the heartbeat transmission over the Ethernet or cellular network is enabled, using the **TL2803G(R)E/3G2080(R)E/TL280(R)E** with a compatible control unit listed for standard/encrypted line security, it can provide line security for the alarm system over the primary line.
- The **TL2803G(R)E/3G2080 (R)E/TL280(R)E/LE2080 (R)X/TL280LE(R)X** is also suitable to be used with a compatible control unit listed for dual line security transmission when used in conjunction with a DACT or a Public Switched Data Network (PSDN) transmitter, where the PSDN provides the line security and is the primary line. In this mode, alarm signals are required to be sent simultaneously over both communication methods.
- For installation in Canada the communicator shall use the locations and wiring methods in accordance with CSA C22.1, Canadian Electrical Code, Part I, Section 32 Safety Standard for Electrical Installations; CAN/ULC S302, Standard for the Installation, Inspection and Testing of Intrusion Alarm Systems; and CAN/ULC S301, Standard for Signal Receiving Centre Intrusion Alarm Systems and Operations.
- For installations in USA the communicator shall use locations and wiring methods in accordance with the Standard for Installation and Classification of Burglar and Holdup Alarm Systems, UL 681, and shall provide for the transmission of status change signals to a monitoring station in accordance with the Standard for Central-Station Alarm Services, UL 827. The loss of communication with the monitoring station shall be treated as an alarm condition by monitoring station personnel when the burglar alarm system is in the armed state, and as a trouble condition while the system is disarmed.
- Packet switched data network (PSDN) interface equipment, that is not provided with the burglar alarm system and/or not required for the processing of the signals shall be evaluated to the applicable requirements of the Standard for Information Technology Equipment - Safety - Part 1: General Requirements, UL 60950-1, or the Standard for Audio/Video, Information and Communication Technology Equipment - Part 1: Safety Requirements, UL 62368-1, as communication equipment. Any network interface device which adds value or manipulates the original data packet such as changing transmission formats, adding encryption, and the like, shall comply with the applicable requirements in UL 2610.

© 2023 Tyco Security Products. All Rights Reserved.  
Tech Support: 1-800-387-3630 (Canada & U.S.) or 905-760-3000  
[www.dsc.com](http://www.dsc.com)

The trademarks, logos, and service marks displayed on this document are registered in the United States [or other countries]. Any misuse of the trademarks is strictly prohibited and Tyco will aggressively enforce its intellectual property rights to the fullest extent of the law, including pursuit of criminal prosecution wherever necessary. All trademarks not owned by Tyco are the property of their respective owners, and are used with permission or allowed under applicable laws. Product offerings and specifications are subject to change without notice. Actual products may vary from photos. Not all products include all features. Availability varies by region; contact your sales representative.

**DSC**

*From Tyco Security Products*



29009553R010